

2006 | 2007

*This booklet is provided
free of charge.*

The **ACT**[®]

PREPARING FOR THE ACT



What's Inside:

- Full-Length Practice Tests, including Writing
- Information about the Optional Writing Test
- Strategies to Prepare for the Tests
- What to Expect on Test Day

ACT[®]

Preparing for the ACT

Contents

1. General Preparation for the ACT® Tests	2
2. Strategies for Taking the ACT Tests	5
3. What to Expect on Test Day	11
4. Taking the Practice Tests.	12
Practice Multiple-Choice Tests	13
Practice Writing Test	57
5. Scoring Your Tests.	59
How to Score the Multiple-Choice Tests.	59
How to Score the Writing Test	67
6. Sample Answer Document	73
Multiple-Choice Tests	73
Writing Test.	75

A Message to Students

This booklet, which is provided **free of charge**, is intended to help you do your best on the ACT. It summarizes general test-taking strategies, describes the content of each of the tests, provides specific tips for each, and lets you know what you can expect on test day. Included in this booklet are a **complete practice test**—“retired” ACT questions that were administered to students on a national test date and a writing prompt—sample answer documents, and scoring instructions.

Read this booklet carefully and take the practice test well before test day so you will be familiar with the tests, what they measure, and the strategies you can use to do your best.

ACT is committed to representing the diversity of our society in all its aspects, including race, ethnicity, and gender. Thus, test passages, questions, and writing prompts are deliberately chosen to reflect the range of cultures in our population.

We also are committed to ensuring that test questions and writing prompts are fair—that they do not disadvantage any particular group of examinees. Extensive reviews of the fairness of test materials are rigorously conducted by both ACT staff and external consultants. We also employ statistical procedures to help ensure that our test materials do not unfairly affect the performance of any group.

Additional ACT Preparation Materials

- **ACT Online Prep™**: The only online test preparation program designed by ACT test development professionals. ACT Online Prep has practice test questions, a practice essay with real-time scoring, a diagnostic test, and personalized Study Path. You can access ACT Online Prep via the Internet anywhere and at any time.
- The **Real ACT Prep Guide** is the official print guide to the ACT. This book includes three practice ACTs previously used in actual test administrations—each with an optional Writing Test, with explanations for all right and wrong answer choices.

ACT Online Prep and the *Real ACT Prep Guide* are available at www.actstudent.org.

1

General Preparation for the ACT Tests

Choosing a Test Option

Students testing in the United States may register for one of two Test Options: the ACT, or the ACT Plus Writing, which includes a 30-minute Writing Test for an additional fee. The ACT Writing Test complements the ACT English Test. The combined results from both tests provide information about your understanding of the conventions of standard written English and your ability to produce a direct sample of your writing. Taking the ACT Plus Writing will provide you with two additional scores: a Writing Test subscore and a Combined English/Writing score. Taking the Writing Test does **not** affect your subject area scores or your Composite score.

Not all institutions require or recommend taking the ACT Writing Test. Check directly with the institutions you are considering to find out their requirements, or ask your high school counselor which Test Option you should take. You can also check our website (www.actstudent.org) for a list of institutions that have provided information to us about their policies—whether they require, recommend, or do not need results from the ACT Writing Test. Consult this list before you register so you will know which Test Option to select.

The ACT Plus Writing is available on national test dates and for Special and Arranged Testing within the United States during designated testing windows. This Test Option is also available on two test dates outside the U.S.

ACT endorses the *Code of Fair Testing Practices in Education* and the *Code of Professional Responsibilities in Educational Measurement*, guides to the conduct of those involved in educational testing. ACT is committed to ensuring that each of its testing programs upholds the guidelines in each *Code*. A copy of each *Code* may be obtained free of charge from ACT Customer Services (68), P.O. Box 1008, Iowa City, IA 52243-1008, 319/337-1429.

© 2006 by ACT, Inc. All rights reserved.

NOTE: This booklet is covered by federal copyright laws that prohibit the reproduction of the test questions without the express, written permission of ACT, Inc.

Choosing a Test Date

Before you choose a test date, consider the application deadlines of the colleges and scholarship agencies that are of interest to you. It will take four to seven weeks after a test date for ACT to mail your score report to you and to your college or agency choices.

Many college and scholarship agencies recommend that students take the ACT during the spring of their junior year. By this time, students typically have completed most of the coursework covered by the ACT. There are a number of advantages in taking the ACT then:

- You will receive test scores and other information that will help you plan your senior year in high school.
- Many colleges begin contacting prospective students during the summer before their senior year.
- If you do not score as well as you believe you can, there will be opportunities to retake the ACT in the fall of your senior year and still have the new information available in time to meet admission and scholarship deadlines.

NOTE: You cannot plan on receiving your scores from one national test date in time to register for the next.

General Test-Taking Strategies for the ACT

The ACT contains multiple-choice tests in four areas: English, Mathematics, Reading, and Science. Each of these tests contains questions that offer either four or five answer choices from which you are to choose the correct, or best, answer. The following suggestions apply to the tests in all four areas:

Pace yourself.

The time limits set for each test give nearly everyone enough time to finish all the questions. However, because the English, Reading, and Science Tests contain a considerable amount of text, it is important to pace yourself so you will not spend too much time on one passage. Similarly, try not to spend too much time puzzling over an answer to a specific problem in the Mathematics Test. Go on to the other questions and come back if there is time.

Your supervisor will announce when there are five minutes remaining on each test.

Read the directions for each test carefully.

Before you begin taking one of the tests, read the directions carefully. The English, Reading, and Science Tests ask for the “best” answer. Do not respond as soon as you identify a correct answer. Read and consider all of the answer choices and choose the answer that *best* responds to the question.

The Mathematics Test asks for the “correct” answer. Read each question carefully to make sure you understand the type of answer required. Then, you may want to work out the answer you feel is correct and look for it among the choices given. If your answer is not among the choices provided, reread the question and consider all of the answer choices.

Read each question carefully.

It is important that you understand what each question asks. Some questions will require you to go through several steps to find the correct or best answer, while others can be answered more quickly.

Answer the easy questions first.

The best strategy for taking the tests is to answer the easy questions and skip the questions you find difficult. After answering all of the easy questions, go back and answer the more difficult questions.

Use logic in more difficult questions.

When you return to the more difficult questions, try to use logic to eliminate incorrect answers to a question. Compare the answer choices to each other and note how they differ. Such differences may provide clues as to what the question requires. Eliminate as many incorrect answers as you can, then make an educated guess from the remaining answers.

Answer every question.

Your score on the tests will be based on the number of questions that you answer correctly; **there is no penalty for guessing**. Thus, you should answer every question within the time allowed for each test, even if you have to guess. The supervisor will announce when there are five minutes remaining on each test.

Review your work.

If there is time left after you have answered every question in a test, go back and check your work in that test. Check to be sure that you marked only one answer to each question. You will not be allowed to go back to any other test or mark answers to a test after time has been called on that test.

Be precise in marking your answer document.

Be sure that you fill in the correct ovals on your answer document. Check to be sure that the number of the line of ovals on your answer document is the same as the number of the question you are answering and that you mark only one response for each question.

Erase completely.

If you want to change a multiple-choice answer, be sure to use a soft eraser that will not leave smudges and erase the unintended mark completely. Do not cross out answers or use correction fluid or tape; you must erase. Correction fluid/tape, smudges, or unintended marks may cause errors in scoring.

To students approved to test at national test centers with extended time:

You will be allowed up to five hours total to work on the multiple-choice tests at your own pace, including breaks between tests. If you are also taking the Writing Test, you will be allowed up to 5 hours and 45 minutes total; however, you must complete the multiple-choice tests within 5 hours. You will need to pace yourself through each test in order to complete all tests within the time allowed. For each test, check your work before notifying the supervisor that you are ready to go on to the next test.

General Test-Taking Strategies for the ACT Writing Test

The ACT Writing Test lets you show your skill in planning and composing a short essay. It measures writing proficiencies that are taught in high school and are important for readiness to succeed in entry-level college composition courses.

The following general strategies will help if you take the ACT Writing Test.

Pace yourself.

You will have 30 minutes to write an essay for the ACT Writing Test. It is important to pace yourself in the way that best suits your personal writing strategy. Many writers do best when they spend part of their time planning their essay, most of their time writing the essay, and the last part of their time reviewing the essay to make corrections and small revisions. There is no formula for the best proportion of time to spend planning, writing, and reviewing: writers, topics, and occasions differ too widely for a universal rule to apply. Keep in mind, however, that you are unlikely to have time to draft, revise, and recopy your essay. Therefore, taking a few minutes to plan your essay is a much better strategy than writing a first draft with the intent to copy it over for the final essay.

In general, budget your time in the way that feels best to you based on your experience in taking essay tests in school and in other circumstances when you've done writing within a time limit. Your test supervisor will announce when there are five minutes remaining on the Writing Test.

Read the directions carefully.

Before you begin taking the Writing Test, read the directions carefully. They tell you the aspects of writing on which your essay will be evaluated and give instructions on how to write in the answer folder.

Read the writing prompt carefully.

It is important that you understand exactly what the writing prompt asks you to do. A firm grasp of the assignment is as crucial for the Writing Test as it is for writing essays for class. Be sure you have a clear understanding of the issue in the writing prompt and of the question you must respond to before you start to plan and write your essay.

Write (or print) legibly in the answer folder.

If your readers cannot make out what you have written, they cannot appreciate what you have said, and they will not be able to score your essay. You may write or print your essay, whichever you prefer—but you must do so clearly. You must write your essay using a **soft lead No. 2 pencil** (not a mechanical pencil) and on the lined pages in the answer folder. You may not need all the lined pages, but to ensure you have enough room to finish, do not skip lines.

Make corrections clear.

If you make corrections by using erasures or cross-outs, do so thoroughly. You may write corrections or additions neatly between the lines of your essay, but do not write in the margins of the lined pages.

Preparing for Test Day

Although what you know will determine how well you do on the ACT, your attitudes, emotions, and physical state may also influence your performance. The following tips will help you do your best:

- Be confident in your ability to do well on the ACT. You can do well!
- Be prepared to work hard.
- Know what to expect on test day. Familiarize yourself with the information in this booklet, in the registration booklet, and on ACT's website. NOTE: Most procedures in this booklet refer to testing on a national test date. Procedures may differ slightly if you test outside the United States or through another type of testing. For example, if you test at a national test center, you won't need scratch paper because each page of the Mathematics Test will provide a blank column that you can use for scratch work. Otherwise, you will be provided with scratch paper.
- Take the practice tests and review your responses so you will feel comfortable about the approaching test day.
- Prepare well in advance for the tests. Do not leave preparation to the last minute.
- Get plenty of rest the night before the tests so you will be in good physical condition for taking them.
- Bring the following items with you to the test center:
 1. Your test center admission ticket (if you are testing on a national test date).
 2. Acceptable identification. Your admission ticket is **not** identification. See details on the back of your admission ticket or on our website. If you do not present acceptable identification at the time of check-in, you will not be admitted to test (you will then have to pay a test date change fee to transfer your registration to a different test date.). If you have any questions about acceptable ID, call ACT Test Administration (319/337-1510) *before* test day.
 3. Sharpened soft lead No. 2 pencils with good erasers (no mechanical pencils; no ink, ballpoint, or felt-tip pens). Do **not** bring highlight pens or any other writing instruments; you will not be allowed to use them. If you have registered to take the ACT Writing Test, your essay **must** also be completed in pencil.
 4. A watch so that you can pace yourself during the test. Do **not** bring a watch that has an alarm function. You will not be allowed to set an alarm because it will disturb other students. An announcement will be made by the supervisor when five minutes remain on each test.
 5. A permitted calculator for use on the Mathematics Test, if you wish to use one. (See shaded section on page 5.)

For students testing on national test dates:

- Look for your admission ticket about 2 weeks after we receive your registration (sooner if you register online or re-register by phone).
- If you misplace your admission ticket or have not received it by ten days before the test, call ACT Registration at 319/337-1270 for assistance.
- Check your admission ticket for your Test Option and the location of the test center to which you have been assigned. If you are unfamiliar with the location, do a practice run to see how to get there and how much time you will need to arrive on time.
- Plan to arrive by the time stated on your admission ticket. If you arrive earlier than 7:45 A.M., you will probably have to wait outside until testing personnel have completed their arrangements.
- Be prepared for testing to start after all examinees present at 8:00 A.M. have been checked in and assigned seats.
- Dress comfortably. To conserve energy, your test center may be considerably warmer or cooler on weekends than during the week. Please dress in such a way that you will be comfortable in a variety of temperatures.

2

Strategies for Taking the ACT Tests

The ACT measures the knowledge, understanding, and skills that you have acquired throughout your education. Although the sum total of what a person has learned cannot easily be changed, your performance in a specific area can be affected by adequate preparation, especially if it has been some time since you have taken a course in that area.

There are three strategies that can help you to prepare yourself for the content included in the ACT:

Familiarize yourself with the content of the ACT tests.

Review the information about the tests that is provided on the following pages. Note which content areas make up a large proportion of the tests and which do not. The specific topics included in each content area are examples of possible topics; they do not include all of the possibilities.

Refresh your knowledge and skills in the content areas.

Review those content areas you have studied but do not have freshly in your mind. Spend your time refreshing your knowledge and skills in the content areas that make up large portions of the tests.

Use of Calculators on the ACT Mathematics Test

It is your responsibility to bring a permitted calculator. We regularly update information about which calculators are **prohibited**. To be certain your calculator will be permitted on test day, visit www.actstudent.org or call **800/498-6481** for a recorded message. If you use a prohibited model, you will be dismissed and your answer document will not be scored.

You may use a calculator on the ACT Mathematics Test (but not on any of the other tests in the ACT). You are **not required** to use a calculator. All the problems can be solved without a calculator. If you regularly use a calculator in your math work, you may wish to use one you are familiar with as you take the Mathematics Test. Using a more powerful, but unfamiliar, calculator is not likely to give you an advantage over using the kind you normally use.

You may use any four-function, scientific, or graphing calculator, unless it has features described in the **Prohibited** list. For models on the **Permitted with Modification** list, you will be required to modify some of the calculator's features.

Prohibited Calculators

The following types of calculators are **prohibited**:

- calculators with built-in computer algebra systems—*Prohibited calculators in this category include:*
 - Texas Instruments: All model numbers that begin with **TI-89** or **TI-92**
 - Hewlett-Packard: **hp 48GII** and all model numbers that begin with **hp 40G** or **hp 49G**
 - Casio: **Algebra fx 2.0**, **ClassPad 300**, and all model numbers that begin with **CFX-9970G**
- pocket organizers
- handheld or laptop computers

- electronic writing pads or pen-input devices—The Sharp EL 9600 is permitted.
- calculators built into cellular phones or other electronic communication devices
- calculators with a typewriter keypad (keys in QWERTY format)—*Calculators with letter keys not in QWERTY format are permitted.*

Calculators Permitted with Modification

The following types of calculators are **permitted, but only after they are modified as noted**:

- calculators with paper tape—*Remove the tape.*
- calculators that make noise—*Turn off the sound.*
- calculators that can communicate wirelessly with other calculators—*Completely cover the infrared data port with heavy opaque material, such as duct tape or electrician's tape.*
- calculators that have power cords—*Remove all power/electrical cords.*

On Test Day

Be sure your calculator is working and has reliable batteries. You may bring a spare calculator and extra batteries to the test center. Testing staff will **not** supply batteries or calculators. You will **not** be allowed to share calculators during testing.

Testing staff will check your calculator to verify it is a permitted type, and they will monitor your use of your calculator to ensure that you:

- use it only during the Mathematics Test;
- use your backup calculator only if your primary calculator fails;
- do not share your calculator; and
- do not store test materials in your calculator's memory.

If your calculator has characters one inch high or larger, or a raised display, testing staff may seat you where no other examinee can see your calculator.

Identify the content areas you have not studied.

If unfamiliar content areas make up major portions of the tests, consider taking coursework to help you gain knowledge and skills in these areas before you take the ACT. Because the ACT measures knowledge and skills acquired over a period of time, it is unlikely that a “cram” course covering material that is unfamiliar to you will help you improve your scores. Longer-term survey courses will be most helpful to you, because they aim to improve your knowledge through sustained learning and practice.

ACT English Test

The English Test is a 75-question, 45-minute test that measures your understanding of the conventions of standard written English (punctuation, grammar and usage, and sentence structure) and of rhetorical skills (strategy, organization, and style). Spelling, vocabulary, and rote recall of rules of grammar are not tested. The test consists of five essays, or passages, each of which is accompanied by a sequence of multiple-choice test questions. Different passage types are employed to provide a variety of rhetorical situations. Passages are chosen not only for their appropriateness in assessing writing skills but also to reflect students’ interests and experiences.

Some questions refer to underlined portions of the passage and offer several alternatives to the portion underlined. You must decide which choice is most appropriate in the context of the passage. Some questions ask about an underlined portion, a section of the passage, or the passage as a whole. You must decide which choice best answers the question posed. Many questions offer “NO CHANGE” to the passage as one of the choices. The questions are numbered consecutively. Each question number refers to a correspondingly numbered portion underlined in the passage or to a correspondingly numbered numeral in a box located at the appropriate point in the passage.

Three scores are reported for the ACT English Test: a total test score based on all 75 questions, a subscore in Usage/Mechanics based on 40 questions, and a subscore in Rhetorical Skills based on 35 questions.

Tips for Taking the ACT English Test

Pace yourself.

The ACT English Test contains 75 questions to be completed in 45 minutes. If you spend 1½ minutes skimming through each passage before responding to the questions, then you will have 30 seconds to answer each question. If possible, spend less time on each question and use the remaining time allowed for this test to review your work and return to the questions that were most difficult for you.

Be aware of the writing style used in each passage.

The five passages cover a variety of topics and are written in a variety of styles. It is important that you take into account the writing style used in each passage when you respond to the questions. In responding to a question, be sure to understand the context of the question. Consider how the sentence containing an underlined portion fits in with the surrounding sentences and into the passage as a whole.

Examine the underlined portions of the passage.

Before responding to a question with an underlined portion, carefully examine what is underlined in the text. Consider the elements of writing that are included in each underlined portion. Some questions will ask you to base your decision on some specific element of writing, such as the tone or emphasis the text should convey. Some questions will ask you to choose the alternative to the underlined portion that is NOT or LEAST acceptable. The answer choices for each question will contain changes in one or more of those elements of writing.

Be aware of questions with no underlined portions.

You will be asked some questions about a section of the passage or about the passage as a whole, in light of a given rhetorical situation. Questions of this type are often identified by a question number in a box located at the appropriate point in the passage. Questions asking global questions about the entire passage are placed at the end of the passage and introduced by a horizontal box enclosing the following instruction: “Questions ___ and ___ ask about the preceding passage as a whole.”

Note the differences in the answer choices.

Many of the questions in the test will involve more than one aspect of writing. Examine each answer choice and how it differs from the others. Be careful not to select an answer that corrects one error but causes a different error.

Determine the best answer.

Two approaches can be taken to determine the best answer to a question in which you are to choose the best alternative to an underlined portion. In the first approach, you can reread the sentence or sentences, substituting each of the possible answer choices for the underlined portion to determine the best choice. In the second approach, you can decide how the underlined portion might best be phrased in standard written English or in terms of the particular question posed. If you think the underlined portion is the best answer, you should select “NO CHANGE.” If not, you should check to see whether your phrasing is one of the other answer choices. If you do not find your phrasing, you should choose the best of the answers presented. For questions cued by a number in a box, you must decide which choice is most appropriate in terms of the question posed or the stated rhetorical situation.

Reread the sentence, using your selected answer.

Once you have selected the answer you feel is best, reread the corresponding sentence(s) of the passage, inserting your selected answer at the appropriate place in the text to make sure it is the best answer within the context of the passage.

Content Covered by the ACT English Test

Six elements of effective writing are included in the English Test: punctuation, grammar and usage, sentence structure, strategy, organization, and style. The questions covering punctuation, grammar and usage, and sentence structure make up the Usage/Mechanics subscore. The questions covering strategy, organization, and style make up

the Rhetorical Skills subscore. A brief description and the approximate percentage of the test devoted to each element of effective writing are given below.

Usage/Mechanics

Punctuation (13%). Questions in this category test your knowledge of the conventions of internal and end-of-sentence punctuation, with emphasis on the relationship of punctuation to meaning (for example, avoiding ambiguity, indicating appositives).

Grammar and Usage (16%). Questions in this category test your understanding of agreement between subject and verb, between pronoun and antecedent, and between modifiers and the word modified; verb formation; pronoun case; formation of comparative and superlative adjectives and adverbs; and idiomatic usage.

Sentence Structure (24%). Questions in this category test your understanding of relationships between and among clauses, placement of modifiers, and shifts in construction.

Rhetorical Skills

Strategy (16%). Questions in this category test how well you develop a given topic by choosing expressions appropriate to an essay's audience and purpose; judging the effect of adding, revising, or deleting supporting material; and judging the relevancy of statements in context.

Organization (15%). Questions in this category test how well you organize ideas and choose effective opening, transitional, and closing sentences.

Style (16%). Questions in this category test how well you choose precise and appropriate words and images, maintain the level of style and tone in an essay, manage sentence elements for rhetorical effectiveness, and avoid ambiguous pronoun references, wordiness, and redundancy.

ACT Mathematics Test

The ACT Mathematics Test is a 60-question, 60-minute test designed to assess the mathematical skills students have typically acquired in courses taken up to the beginning of grade 12. The test presents multiple-choice questions that require you to use reasoning skills to solve practical problems in mathematics. Most questions are discrete, but on occasion some may belong to sets of several questions (e.g., several questions based on the same graph or chart). Knowledge of basic formulas and computational skills are assumed as background for the problems, but complex formulas and extensive computation are not required. The material covered on the test emphasizes the major content areas that are prerequisites to successful performance in entry-level courses in college mathematics.

Use of calculators is permitted on the Mathematics Test. See page 5 for details.

Four scores are reported for the ACT Mathematics Test: a total test score based on all 60 questions, a subscore in Pre-Algebra/Elementary Algebra based on 24 questions, a subscore in Intermediate Algebra/Coordinate Geometry based on 18 questions, and a subscore in Plane Geometry/Trigonometry based on 18 questions.

Tips for Taking the ACT Mathematics Test

Pace yourself.

The ACT Mathematics Test contains 60 questions to be completed in 60 minutes. The maximum estimated time that should be spent on each question is 1 minute. If possible, spend less time on each question and use the remaining time allowed for this test to review your work and return to the questions on this test that were most difficult for you.

If you use a calculator, use it wisely.

Remember, all of the mathematics problems can be solved without using a calculator. In fact, some of the problems are best done without a calculator. Use good judgment in deciding when, and when not, to use a calculator. For example, for some problems you may wish to do scratch work to clarify your thoughts on the question before you begin using a calculator to do computations. For many problems, you may not want to use a calculator.

Solve the problem.

For working out the solutions to the problems, writing space for scratch work usually is available in the test booklet, or you will be given scratch paper to use. You may wish to glance over the answer choices after reading the questions. However, working backwards from the answer choices provided can take a lot of time and may not be effective.

Locate your solution among the answer choices.

Once you have solved the problem, look for your answer among the choices. If your answer is not included among the choices, carefully reread the problem to see whether you missed important information. Pay careful attention to the question being asked. If an equation is to be selected, check to see whether the equation you think is best can be transformed into one of the answer choices provided.

Make sure you answer the question.

The solutions to many questions in the test will involve several steps. Make sure your answer includes all of the necessary steps. Frequently, questions include answer choices that are based on incomplete solutions.

Make sure your answer is reasonable.

Sometimes an error in computation will result in an answer that is not practically possible for the situation described. Always think about your answer to determine whether it is reasonable.

Check your work.

You may arrive at an incorrect solution by making common errors in the problem-solving process. Thus, if there is time available before the end of the Mathematics Test, it is important that you reread the questions and check your answers to make sure they are correct.

Content Covered by the ACT Mathematics Test

Six content areas are included in the Mathematics Test: pre-algebra, elementary algebra, intermediate algebra, coordinate geometry, plane geometry, and trigonometry. The questions covering pre-algebra and elementary algebra make up the Pre-Algebra/Elementary Algebra subscore. The questions covering intermediate algebra and coordinate geometry make up the Intermediate Algebra/Coordinate

Geometry subscore. And the Plane Geometry/Trigonometry subscore is based on the questions covering plane geometry and trigonometry. A brief description and the approximate percentage of the test devoted to each content area are given below.

Pre-Algebra/Elementary Algebra

Pre-Algebra (23%). Questions in this content area are based on basic operations using whole numbers, decimals, fractions, and integers; place value; square roots and approximations; the concept of exponents; scientific notation; factors; ratio, proportion, and percent; linear equations in one variable; absolute value and ordering numbers by value; elementary counting techniques and simple probability; data collection, representation, and interpretation; and understanding simple descriptive statistics.

Elementary Algebra (17%). Questions in this content area are based on properties of exponents and square roots, evaluation of algebraic expressions through substitution, using variables to express functional relationships, understanding algebraic operations, and the solution of quadratic equations by factoring.

Intermediate Algebra/Coordinate Geometry

Intermediate Algebra (15%). Questions in this content area are based on an understanding of the quadratic formula, rational and radical expressions, absolute value equations and inequalities, sequences and patterns, systems of equations, quadratic inequalities, functions, modeling, matrices, roots of polynomials, and complex numbers.

Coordinate Geometry (15%). Questions in this content area are based on graphing and the relations between equations and graphs, including points, lines, polynomials, circles, and other curves; graphing inequalities; slope; parallel and perpendicular lines; distance; midpoints; and conics.

Plane Geometry/Trigonometry

Plane Geometry (23%). Questions in this content area are based on the properties and relations of plane figures, including angles and relations among perpendicular and parallel lines; properties of circles, triangles, rectangles, parallelograms, and trapezoids; transformations; the concept of proof and proof techniques; volume; and applications of geometry to three dimensions.

Trigonometry (7%). Questions in this content area are based on understanding trigonometric relations in right triangles; values and properties of trigonometric functions; graphing trigonometric functions; modeling using trigonometric functions; use of trigonometric identities; and solving trigonometric equations.

ACT Reading Test

The Reading Test is a 40-question, 35-minute test that measures your reading comprehension. The test questions ask you to derive meaning from several texts by (1) referring to what is explicitly stated and (2) reasoning to determine implicit meanings. Specifically, questions will ask you to use referring and reasoning skills to determine main ideas; locate and interpret significant details; understand sequences of events; make comparisons; comprehend cause-effect rela-

tionships; determine the meaning of context-dependent words, phrases, and statements; draw generalizations; and analyze the author's or narrator's voice and method. The test comprises four prose passages that are representative of the level and kinds of text commonly encountered in college freshman curricula. Each passage is preceded by a heading that identifies what type of passage it is (for example, "Prose Fiction"), names the author, and may include a brief note that helps in understanding the passage. Each passage is accompanied by a set of multiple-choice test questions. These questions do not test the rote recall of facts from outside the passage, isolated vocabulary items, or rules of formal logic.

Three scores are reported for the ACT Reading Test: a total test score based on all 40 questions, a subscore in Social Studies/Sciences reading skills (based on the 20 questions in the social studies and natural sciences sections of the test), and a subscore in Arts/Literature reading skills (based on the 20 questions in the prose fiction and humanities sections of the test).

Tips for Taking the ACT Reading Test

Pace yourself.

The ACT Reading Test contains 40 questions to be completed in 35 minutes. If you spend 2–3 minutes reading each passage, then you will have about 35 seconds to answer each question. If possible, spend less time on the passages and the questions and use the remaining time allowed for this test to review your work and return to the questions on this test that were most difficult for you.

Read the passage carefully.

Before you begin answering a question, read the entire passage thoroughly. It is important that you read every sentence rather than skim the text. Be conscious of relationships between or among ideas. You may want to make notes about important ideas in the passage either in the test booklet or on the scratch paper provided.

Refer to the passage when answering the questions.

Answers to some of the questions will be found by referring to what is explicitly stated in the text. Other questions will require you to determine implicit meanings and to draw conclusions, comparisons, and generalizations. Refer to the passage before you answer any question.

Content Covered by the ACT Reading Test

The Reading Test is based on four types of reading selections: the social studies, the natural sciences, prose fiction, and the humanities. A subscore in Social Studies/Sciences reading skills is based on the questions in the social studies and the natural sciences sections of the test, and a subscore in Arts/Literature reading skills is based on the questions in the prose fiction and humanities sections of the test. A brief description and the approximate percentage of the test devoted to each type of reading selection are given below.

Social Studies (25%). Questions in this category are based on passages in the content areas of anthropology, archaeology, biography, business, economics, education, geography, history, political science, psychology, and sociology.

Natural Sciences (25%). Questions in this category are based on passages in the content areas of anatomy, astronomy, biology, botany, chemistry, ecology, geology, medicine, meteorology, microbiology, natural history, physiology, physics, technology, and zoology.

Prose Fiction (25%). Questions in this category are based on intact short stories or excerpts from short stories or novels.

Humanities (25%). Questions in this category are based on passages from memoirs and personal essays and in the content areas of architecture, art, dance, ethics, film, language, literary criticism, music, philosophy, radio, television, and theater.

ACT Science Test

The Science Test is a 40-question, 35-minute test that measures the interpretation, analysis, evaluation, reasoning, and problem-solving skills required in the natural sciences.

The test presents seven sets of scientific information, each followed by a number of multiple-choice test questions. The scientific information is conveyed in one of three different formats: data representation (graphs, tables, and other schematic forms), research summaries (descriptions of several related experiments), or conflicting viewpoints (expressions of several related hypotheses or views that are inconsistent with one another). The questions require you to recognize and understand the basic features of, and concepts related to, the provided information; to examine critically the relationship between the information provided and the conclusions drawn or hypotheses developed; and to generalize from given information to gain new information, draw conclusions, or make predictions. The use of calculators is **not** permitted on the Science Test.

One score is reported for the ACT Science Test: a total test score based on all 40 questions.

Tips for Taking the ACT Science Test

Pace yourself.

The ACT Science Test contains 40 questions to be completed in 35 minutes. If you spend about 2 minutes reading each passage, then you will have about 30 seconds to answer each question. If possible, spend less time on the passages and the questions and use the remaining time allowed for this test to review your work and return to the questions on this test that were most difficult for you.

Read the passage carefully.

Before you begin answering a question, read the scientific material provided. It is important that you read the entire text and examine any tables, graphs, or figures. You may want to make notes about important ideas in the information provided, either in the test booklet or on the scratch paper provided. Some of the information sets will describe experiments. You should consider the experimental design, including the controls and variables, because questions are likely to address this component of scientific research.

Note different viewpoints in passages.

Some material will present conflicting points of view, and the questions will ask you to distinguish among the various viewpoints. It may be helpful for you to make notes

summarizing each viewpoint, either next to that section in your test booklet (or if you are testing outside the U.S., on the scratch paper provided). For questions that ask you to compare viewpoints, these notes will help you answer more quickly.

Content Covered by the ACT Science Test

The content of the Science Test includes biology, chemistry, physics, and the Earth/space sciences (for example, geology, astronomy, and meteorology). Advanced knowledge in these subjects is not required, but knowledge acquired in general, introductory science courses is needed to answer some of the questions. The test emphasizes scientific reasoning skills over recall of scientific content, skill in mathematics, or reading ability. The scientific information is conveyed in one of three different formats.

Data Representation (38%). This format presents graphic and tabular material similar to that found in science journals and texts. The questions associated with this format measure skills such as graph reading, interpretation of scatterplots, and interpretation of information presented in tables.

Research Summaries (45%). This format provides descriptions of one or more related experiments. The questions focus upon the design of experiments and the interpretation of experimental results.

Conflicting Viewpoints (17%). This format presents expressions of several hypotheses or views that, being based on differing premises or on incomplete data, are inconsistent with one another. The questions focus upon the understanding, analysis, and comparison of alternative viewpoints or hypotheses.

ACT Writing Test (Optional)

If you register for the ACT Plus Writing, you will take the ACT Writing Test (which must be completed in English) after you complete the four multiple-choice tests. Taking the Writing Test will **not** affect your scores on the multiple-choice tests or the Composite score for those tests. Rather, you will receive two additional scores: a Combined English/Writing score on a scale of 1 through 36 and a Writing subscore on a scale of 2 through 12. You will also receive some comments on your essay. And your essay will be available to your high school and the colleges to which we report your scores from that test date.

The Writing Test is a 30-minute essay test that measures your writing skills—specifically those writing skills emphasized in high school English classes and in entry-level college composition courses. The test consists of one writing prompt that will define an issue and describe two points of view on that issue. You are asked to write in response to a question about your position on the issue described in the writing prompt. In doing so, you may adopt one or the other of the perspectives described in the prompt, or you may present a different point of view on the issue. Your essay score will not be affected by the point of view you take on the issue. Prompts are designed to be appropriate for response in a 30-minute timed test and to reflect students' interests and experiences.

Your essay will be evaluated on the evidence it gives of your ability to do the following:

- express judgments by taking a position on the issue in the writing prompt;
- maintain a focus on the topic throughout the essay;
- develop a position by using logical reasoning and by supporting your ideas;
- organize ideas in a logical way; and
- use language clearly and effectively according to the conventions of standard written English.

Your essay will be scored holistically—that is, on the basis of the overall impression created by all the elements of the writing. Two trained readers will read your essay, each giving it a rating from 1 (low) to 6 (high). The sum of those ratings is your Writing subscore. If the readers' ratings disagree by more than one point, a third reader will evaluate your essay and resolve the discrepancy.

Tips for Taking the ACT Writing Test

Pace yourself.

The ACT Writing Test gives you 30 minutes to read and think about the issue in the prompt, and to plan and write your essay. When asked to write a timed essay, most writers find it useful to do some planning before they write the essay, and to do a final check of the essay when it is finished. It is unlikely that you will have time to draft, revise, and recopy your essay. Therefore, taking a few minutes to plan your essay is a much better strategy than writing a first draft with the intent to copy it over for the final essay.

Prewrite.

Some writers like to plunge right in, but this is seldom a good way to do well on a timed essay. Prewriting gets you acquainted with the issue, suggests patterns for presenting your thoughts, and gives you a little breathing room to come up with interesting ideas for introducing and concluding your essay. Before writing, then, carefully consider the prompt and make sure you understand it—reread it if you aren't sure. Decide how you want to answer the question in the prompt. Then jot down your ideas on the topic: this might simply be a list of ideas, reasons, and examples that you will use to explain your point of view on the issue. Write down what you think others might say in opposition to your point of view and think about how you would refute their argument. Think of how best to organize the ideas in your essay. You will be instructed to do your prewriting in your Writing Test booklet. You can refer back to these notes as you write the essay itself on the lined pages in your answer folder.

Write.

Once you're ready to write your essay in the answer folder, proceed with the confidence that you have prepared well and that you will have attentive and receptive readers who are interested in your ideas. At the beginning of your essay, make sure readers will see that you understand the issue. Explain your point of view in a clear and logical way. If possible, discuss the issue in a broader context or evaluate the implications or complications of the issue. Address what others might say to refute your point of view and present a counterargument. Use specific examples. Vary the structure of your sentences, and use varied and precise word choices. Make logical relationships clear by using transitional words and phrases. Do not wander off the topic. End with a strong conclusion that summarizes or reinforces your position.

Is it advisable to organize the essay by using a formula, like "the five-paragraph essay"? Points are neither awarded nor deducted for following familiar formulas, so feel free to use one or not as best suits your preference. Some writers find formulas stifling, other writers find them vital, and still other writers just keep them handy in the toolbox to use when needed. The exact numbers of words and paragraphs in your essay are less important than the clarity and development of your ideas. Writers who have something to say usually find that their ideas have a way of sorting themselves out at reasonable length and in the right number of paragraphs.

Review your essay.

Take a few minutes before the end of the testing session to read over your essay. Correct any mistakes in grammar, usage, punctuation, and spelling. If you find any words that are hard to read, recopy them so your readers can read them easily. Make any corrections and revisions neatly, between the lines (but not in the margins). Your readers take into account that you had merely 30 minutes to compose and write your essay. Within that time limit, try to make your essay as polished as you can.

Practice.

There are many ways to prepare for the ACT Writing Test. You may be surprised that these include reading newspapers and magazines, listening to news analyses on television or radio, and participating in discussions and debates about issues and problems. These activities help you become more familiar with current issues, with different perspectives on those issues, and with strategies that skilled writers and speakers use to present their points of view.

Of course, one of the best ways to prepare for the ACT Writing Test is to practice writing. Practice writing different kinds of texts, for different purposes, with different audiences in mind. The writing you do in your English classes will help you. So will practice in writing essays, stories, poems, plays, editorials, reports, letters to the editor, a personal journal, or other kinds of writing that you do on your own. Because the ACT Writing Test asks you to explain your perspective on an issue in a convincing way, writing opportunities like editorials or letters to the editor of a newspaper are especially helpful. Practicing a variety of different kinds of writing will help make you a versatile writer able to adjust to different writing occasions and assignments.

It is also a good idea to get some practice writing within a time limit. This will help build skills that are important in college-level learning and in the world of work. Taking the practice ACT Writing Test in this booklet will give you a good idea of what timed writing is like and how much additional practice you may need. You might want to take the practice ACT Writing Test even if you do not plan to register for it, because all the writing you do contributes to your skill in expressing yourself.

Content Covered by the ACT Writing Test

Writing is where form and content come together. To state that more accurately, writing is where *you* put form and content together. On the ACT Writing Test, we provide the "prompt"—an issue that has been chosen for its appropriateness in a 30-minute test and for its relevance to students' interests and experiences. The prompt defines the topic and sets you the task of focusing on that topic in your essay. But the "content"—the arguments and explanations, the analysis

and examples, in all their details—is provided by you. By applying your writing skills to shaping that content, you also provide the “form” of your essay. So, with regard to the content covered by the Writing Test, you are the author.

3

What to Expect on Test Day

Identification Required

You are to report to the test center by the time stated on your admission ticket, normally 8:00 A.M. If your admission ticket does not list a specific room, test center staff or posted signs will direct you to the test room. **At check-in, you will be required to show BOTH your admission ticket and acceptable ID.** See ID requirements on the back of your admission ticket, at www.actstudent.org, or in *Registering for the ACT*.

Dos and Don'ts

In the test room, the supervisor or proctor will direct you to a seat. If you need a left-handed desk, tell your supervisor as you enter. Do not leave the test room after you have been admitted. Only pencils, erasers, a calculator (for the Mathematics Test only), and your admission ticket will be allowed on your desk. You will be required to put all other personal belongings away. You will not be allowed to have scratch paper (unless provided by the test supervisor for certain types of testing), books, dictionaries, notes or other aids, highlighters, colored pens or pencils, correction fluid, reading material, or any electronic devices other than permitted calculators (examples include pager, timer, beeper, cell phone, CD/tape player, PDA, headphones, camera). You may not eat, use tobacco in any form, or have food or drink (including water) in the test room. You must abide by the rules of the institution where you are testing.

Try to relax just before the tests. Take a few deep breaths, tense and relax your muscles, and think about pleasant things.

Test Preliminaries

The test session will begin as soon as all examinees present at 8:00 A.M. are checked in. Listen carefully to all directions read by the supervisor. Ask questions if you do not understand what you are to do. It is very important that you *follow all directions* carefully. For instance, if you do not copy the matching information from your admission ticket onto your answer document accurately, or fill in the correct ovals, your answer document will not match your registration record—and the reporting of your scores will take three to five weeks longer than usual to process.

You will receive a different answer document depending on which Test Option you have registered to take. Make sure

the answer document you receive matches the Test Option you intend to take.

After you have completed page 1 of the answer document, you will receive a test booklet. You will be told to read the directions printed on the cover, then asked to write the booklet number and test form at the top of page 2 of the answer document. It is extremely important that you fill in the correct ovals for your test booklet number and for the test form you are taking because these determine which answer key will be used to score your answer document. The supervisor will then tell you when to open your test booklet and begin work. If you are taking the ACT Plus Writing, you will receive a Writing Test booklet only after you have completed the four multiple-choice tests.

Taking the Tests

As you are working, keep your eyes on your own test booklet and answer document. If you have a question, raise your hand, but do not look around. Please remember that as you take the tests you may not use information or materials that cause you to obtain a test score that misrepresents what you have learned.

It is important that you understand what is considered prohibited behavior on the ACT Assessment. If you are involved in **any** of the actions listed below, you will have to return your test materials and leave the test center. Prohibited behaviors include:

- filling in or altering any ovals or continuing to write the essay after time is called on each test (You must put down your pencil when time is called.)
- looking at another examinee's test booklet or answer document
- giving or receiving assistance
- looking back at a test on which time has been called
- looking ahead in the test booklet
- using highlight pens, colored pens or pencils, notes, dictionaries, or other aids
- using an unauthorized calculator
- using any device to share or exchange information at any time during testing or during breaks (all electronic devices, including cell phones and pagers, must be turned off from the time you are admitted to test until you are dismissed after testing concludes)
- sharing a calculator with another examinee
- using a calculator on any test other than the Mathematics Test
- attempting to remove test materials, including questions or answers, from the test room by any means
- not following instructions or abiding by the rules of the test center
- exhibiting confrontational, threatening, or unruly behavior
- creating a disturbance or allowing an alarm, pager, or phone to sound in the test room

All of the above activities are prohibited. If you engage in any prohibited behavior, your answer document will **not** be scored and you will be dismissed from the test center.

If you finish before time is called, review your work on the test you have just finished. Do **not** return to an earlier test and do not work ahead. If you are satisfied with your responses, place your answer document inside your test booklet and close the cover. Sit quietly until the supervisor gives you additional instructions.

Taking the Practice Tests

Taking the practice tests can help you become familiar with the ACT. It will be most helpful if you take the tests under conditions that are as similar as possible to those you will experience on the actual test day. The following tips will help you make the most of the practice tests:

- The four multiple-choice tests require a total of 2 hours and 55 minutes. Try to take them in one sitting, with only a short break between Tests 2 and 3. (If you are taking the Writing Test, you may also take a short break after Test 4.)
- Sit at a desk with good lighting. You will need sharpened No. 2 pencils with good erasers. You may not use highlight pens or correction fluid. Remove all books and other aids from your desk. On test day, you will not be allowed to use references or notes. If you test at a national test center, you won't need scratch paper because each page of the Mathematics Test has a blank column that you can use for scratch work. Otherwise, you will be provided with scratch paper.
- If you plan to use a calculator on the Mathematics Test, review the details about permissible calculators on page 5.
- Use a digital timer or clock to time yourself on each test. Set your timer for five minutes less than the allotted time for each test so you can get used to the five-minute warning. (Students approved for extended-time should set a timer for 60-minute warnings up to the total time allowed—5 hours for multiple-choice tests (5 hours and 45 minutes if taking the Writing Test).
- Allow yourself only the time permitted for each test.
- Detach and use the sample multiple-choice answer document on pages 73–74.
- Read the general test directions on the first page of the practice multiple-choice test. These are the same directions that will appear on your test booklet on test day. After you have read the directions, start your timer and begin with Test 1. Continue through Test 4, taking a short break between Tests 2 and 3. If you do not plan to take the ACT Writing Test, score your multiple-choice tests using the information beginning on page 59.
- If you plan to take the Writing Test, take a short break after Test 4. Then read the test directions on the first page of the practice ACT Writing Test (page 57). These are the same directions that will appear on your test booklet on test day. After you have read the directions, start your timer, then carefully read the prompt on page 58. After you have considered what the prompt is asking you to do, use scratch paper to plan your essay and then write your essay on the answer document, pages 75–78. When you have finished, score your essay using the information on pages 66–72.

You will have a short break after the first two tests. Do not leave the building during the break period because some buildings have automatic locking doors, and you may be locked out. You must ask permission to leave the room during testing to go to the rest room; you will not be given time to make up for the time you miss. If you are taking the Writing Test, you will also have a brief break after Test 4 in which to relax and to sharpen your pencils.

On certain test dates, ACT administers test questions for developmental purposes. Responses to such questions are not counted toward your scores.

At the conclusion of the session, you will be asked to read and sign a statement certifying truthful identification of yourself. You will be required to sit quietly until you are dismissed. After all answer documents and test booklets have been collected and counted, the supervisor will dismiss you.

Special Situations

If, for any reason, you have to leave the center before finishing the ACT, you must decide whether or not you want your answer document scored and inform the supervisor of your decision. If you fail to do so, your answer document will be scored. Or, if you decide *after* you have finished the ACT that you do not want it scored, tell the supervisor *before* you leave the test center. You need not give a reason.

Once you break the seal on your multiple-choice test booklet, you cannot later request a test date change. If you want to take the ACT again, you will have to reregister. See www.actstudent.org or *Registering for the ACT*. Once you begin filling out your answer document, you cannot request a different Test Option on that test date (i.e., you may not change from ACT Plus Writing to the ACT or the reverse).

You may not receive scores from more than one test date per national administration (Saturday, non-Saturday, or rescheduled test date arranged by ACT). If you are admitted and allowed to test, you will receive **ONLY** the scores from your first test administration.

Test Information Release

On certain national test dates, you may obtain (for an additional fee) a copy of the test questions, a copy of your answers, a list of correct answers, and scoring instructions. This service is not available for all dates or for other types of testing, so if you want it, be sure to check our website or the registration booklet, *Registering for the ACT*, and register for a test date on which it is available. (Your request must be postmarked no later than three months after the test date.) The information will be mailed about 4 weeks after your score report has been mailed.

Practice Multiple-Choice Tests

Your Signature (do not print): _____

Print Your Name Here: _____

Your Date of Birth:

<input type="text"/>	-	<input type="text"/>	-	<input type="text"/>	<input type="text"/>	<input type="text"/>
----------------------	---	----------------------	---	----------------------	----------------------	----------------------

Month Day Year

Form 0661C



ACT 2006 | 2007 ASSESSMENT®

Directions

This booklet contains tests in English, Mathematics, Reading, and Science. These tests measure skills and abilities highly related to high school course work and success in college. *CALCULATORS MAY BE USED ON THE MATHEMATICS TEST ONLY.*

The questions in each test are numbered, and the suggested answers for each question are lettered. On the answer document, the rows of ovals are numbered to match the questions, and the ovals in each row are lettered to correspond to the suggested answers.

For each question, first decide which answer is best. Next, locate on the answer document the row of ovals numbered the same as the question. Then, locate the oval in that row lettered the same as your answer. Finally, fill in the oval completely. Use a soft lead pencil and make your marks heavy and black. *DO NOT USE A BALLPOINT PEN.*

Mark only one answer to each question. If you change your mind about an answer, erase your first mark thoroughly before marking your new answer. For each question, make certain that you mark in the row of ovals with the same number as the question.

Only responses marked on your answer document will be scored. Your score on each test will be based only on the number of questions you answer correctly during the time allowed for that test. You will NOT be penalized for guessing. *IT IS TO YOUR ADVANTAGE TO ANSWER EVERY QUESTION EVEN IF YOU MUST GUESS.*

You may work on each test ONLY when your test supervisor tells you to do so. If you finish a test before time is called for that test, you should use the time remaining to reconsider questions you are uncertain about in that test. You may NOT look back to a test on which time has already been called, and you may NOT go ahead to another test. To do so will disqualify you from the examination.

Lay your pencil down immediately when time is called at the end of each test. You may NOT for any reason fill in or alter ovals for a test after time is called for that test. To do so will disqualify you from the examination.

Do not fold or tear the pages of your test booklet.

**DO NOT OPEN THIS BOOKLET
UNTIL TOLD TO DO SO.**



P.O. BOX 168
IOWA CITY, IA 52243-0168

©2006 by ACT, Inc. All rights reserved.
NOTE: This booklet is covered by Federal copyright laws that prohibit the reproduction of the test questions without the express, written permission of ACT, Inc.



ENGLISH TEST

45 Minutes—75 Questions

DIRECTIONS: In the five passages that follow, certain words and phrases are underlined and numbered. In the right-hand column, you will find alternatives for the underlined part. In most cases, you are to choose the one that best expresses the idea, makes the statement appropriate for standard written English, or is worded most consistently with the style and tone of the passage as a whole. If you think the original version is best, choose “NO CHANGE.” In some cases, you will find in the right-hand column a question about the underlined part. You are to choose the best answer to the question.

You will also find questions about a section of the passage, or about the passage as a whole. These questions do not refer to an underlined portion of the passage, but rather are identified by a number or numbers in a box.

For each question, choose the alternative you consider best and fill in the corresponding oval on your answer document. Read each passage through once before you begin to answer the questions that accompany it. For many of the questions, you must read several sentences beyond the question to determine the answer. Be sure that you have read far enough ahead each time you choose an alternative.

PASSAGE I

The Music of the O’odham

[1]

For some people, traditional American Indian music is associated and connected¹ with high penetrating vocals accompanied by a steady drumbeat. In tribal communities in the southwestern United States, however, one is likely to hear something similar to the polka-influenced dance music of northern Mexico. The music is called “waila.” Among the O’odham tribes of Arizona, waila has been popular for² more than a century. The music is mainly instrumental³—the bands generally consist of guitar, bass guitar, saxophones, accordion, and drums.

[2]

Unlike some traditional tribal music, waila does not serve a religious or spiritual purpose. It is a social music that performed⁴ at weddings, birthday parties,

- A. NO CHANGE
 B. connected by some of them
 C. linked by association
 D. associated
- F. NO CHANGE
 G. popular, one might say, for
 H. really quite popular for
 J. popular for the duration of
- Which of the following alternatives to the underlined portion would NOT be acceptable?
 A. instrumental; in general, the bands
 B. instrumental, the bands generally
 C. instrumental. The bands generally
 D. instrumental; the bands generally
- F. NO CHANGE
 G. music in which it is performed
 H. music, performing
 J. music, performed

and feasts. The word itself⁵ comes from the Spanish

word for dance, *baile*. Cheek to cheek, the dance is⁶
performed to the relaxed two-step tempo, and the bands⁶

often play long past⁷ midnight. As the dancers step to the

music, they were also stepping⁸ in time to a sound that

embodies their⁹ unique history and suggests the influence

of outside cultures on their music. 10

[3]

The O'odham in the 1700s¹¹ first encountered the
guitars of Spanish missionaries. In the 1850s the O'odham

have borrowed¹² from the waltzes and mazurkas of
people of European descent on their way to California.

5. A. NO CHANGE
B. word, itself,
C. word, itself
D. word itself,
6. F. NO CHANGE
G. Couples dance cheek to cheek to the relaxed two-step tempo,
H. A relaxed two-step tempo, the couples dance cheek to cheek,
J. Cheek to cheek, the two-step tempo relaxes dancing couples,
7. A. NO CHANGE
B. play long, past,
C. play, long past,
D. play, long past
8. F. NO CHANGE
G. are also stepping
H. have also stepped
J. will also step
9. A. NO CHANGE
B. they're
C. it's
D. its'
10. At this point, the writer is considering adding the following true statement:
The agricultural practices of the O'odham are similar to those of the Maya.
Should the writer make this addition here?
F. Yes, because the sentence establishes that the O'odham often borrowed ideas from other groups.
G. Yes, because the sentence provides important information about the O'odham people.
H. No, because the sentence is not supported by evidence of a connection between the O'odham and the Maya.
J. No, because the sentence distracts from the paragraph's focus on waila's uses and influences.
11. All of the following would be acceptable placements for the underlined portion EXCEPT:
A. where it is now.
B. at the beginning of the sentence (revising the capitalization accordingly).
C. after the word *guitars*.
D. after the word *missionaries* (ending the sentence with a period).
12. F. NO CHANGE
G. have been borrowing
H. were borrowed
J. borrowed

In the early 1900s the O’odham became acquainted with marching bands and woodwind instruments

(which explains the presence of saxophones in waila).

13

Around this time the polka music and button accordion

played by German immigrant railroad workers; left their mark on waila.

14

[4]

It should be no surprise that musicians these days are adding touches of rock, country, and reggae to waila. Some listeners fear that an American musical form may soon be lost. But the O’odham are playing waila with as much energy and devotion as ever. A unique blend of traditions, waila will probably continue changing for as long as the O’odham use it to express their own sense of harmony and tempo.

PASSAGE II

How Old Am I?

Many people might be surprised to learn that the American way of computing a person’s age differs from the traditional Korean way. In Korean tradition, a person is considered to be already one year old at the time of his or her birth.

As a child growing up in two cultures, I found this contest a bit confusing. When I was in the fifth grade, was I ten or eleven years old? To add to the

16

confusion, every New Year’s Day a person according to this Korean counting system, becomes a year

17

13. Given that all of the choices are true, which one is most relevant to the focus of this paragraph?

- A. NO CHANGE
- B. (although fiddles were once widely used in waila bands).
- C. (even though they’re now often constructed of metal).
- D. (which are frequently found in jazz bands also).

14. F. NO CHANGE

- G. workers
- H. workers;
- J. workers,

Question 15 asks about the preceding passage as a whole.

15. Upon reviewing this essay and finding that some information has been left out, the writer composes the following sentence incorporating that information:

Those same German influences helped spawn a similar musical form in northern Mexico known as *norteño*.

This sentence would most logically be placed after the last sentence in Paragraph:

- A. 1.
- B. 2.
- C. 3.
- D. 4.

16. F. NO CHANGE

- G. change
- H. dispute
- J. difference

17. A. NO CHANGE

- B. person,
- C. person;
- D. person who,



older, regardless of his or her actual birthday.

Birthdays are important throughout the world. A person ¹⁸ who is sixteen years old on his or her birthday in March would become seventeen years old on the following New Year's Day, even though he or she isn't expected to turn seventeen (in "American" years) until that next birthday in March. Perhaps the celebration of New Year's Day in Korean culture is heightened because it is thought of as ¹⁹

everyone's birthday party. 20

Today, after many birthdays and New Year's Days, I now find meaningful the difference I once found confusing. Otherwise, this difference points ²¹

to significant underlying cultural values. The practice of ²²

advancing a person's age seems to me to reflect the value a ²³

society places on life experience and longevity. Their idea ²⁴

was demonstrated often when my elderly relatives, who ²⁵ took pride in reminding younger folk of their "Korean

age." With great enthusiasm, they added on a year every ²⁶

18. F. NO CHANGE
 G. Most cultures celebrate birthdays.
 H. Birthdays focus attention on a culture's youth.
 J. DELETE the underlined portion.

19. A. NO CHANGE
 B. raised
 C. lifted
 D. lighted

20. Upon reviewing this paragraph, the writer considers deleting the preceding sentence. If the writer were to delete the sentence, the paragraph would primarily lose:
 F. a comment on the added significance of the Korean New Year celebration.
 G. a repetitive reminder of what happens every birthday.
 H. a defense of the case for celebrating every birthday.
 J. an illustration of the Korean counting system.

21. A. NO CHANGE
 B. Though,
 C. In fact,
 D. Then,

22. F. NO CHANGE
 G. on
 H. at
 J. DELETE the underlined portion.

23. A. NO CHANGE
 B. persons' age
 C. persons age
 D. person's age,

24. F. NO CHANGE
 G. One's
 H. Its
 J. This

25. A. NO CHANGE
 B. by
 C. while
 D. as if

26. Which choice would most clearly communicate the elderly relatives' positive attitude toward this practice?
 F. NO CHANGE
 G. Duplicating an accepted practice,
 H. Living with two birthdays themselves,
 J. Obliging,

New Year's Day. By contrast American society has often been described as one that values the vibrant energy of

youth over the wisdom and experience gained with age. 28
After a certain age, many Americans I know would

balk, refuse, and hesitate at the idea of adding a year or two to what they regard as their actual age.

Even something as visibly simple or natural as computing a person's age can prove to be not so clear-cut. Traditions like celebrating birthdays reveal how deeply we are affected by the culture we live in.

27. A. NO CHANGE
B. whose
C. this
D. whom

28. If the writer were to delete the phrases "the vibrant energy of" and "the wisdom and experience gained with" from the preceding sentence, the sentence would primarily lose:
F. its personal and reflective tone.
G. an element of humor.
H. details that illustrate the contrast.
J. the preference expressed by the writer.

29. A. NO CHANGE
B. balk and hesitate
C. refuse and balk
D. balk

30. F. NO CHANGE
G. apparently
H. entirely
J. fully

PASSAGE III

Wearing Jeans in School

In 1970, the school board in Pittsfield, New Hampshire, approved a dress code that prohibited students from wearing certain types of clothing. The school board members believed that wearing "play clothes" to school made the students

inefficient toward their school work, while more formal attire established a positive educational climate. When twelve-year-old Kevin Bannister wore a pair of blue jeans to school, he was sent home for violating the dress code.

31. Given that all of the choices are true, which one would best illustrate the term *dress code* as it is used in this sentence?
A. NO CHANGE
B. clothing that was inappropriate.
C. clothing, including sandals, bell-bottom pants, and "dungarees" (blue jeans).
D. clothing that is permitted in some schools today.
32. F. NO CHANGE
G. lazy and bored to tears with
H. blow off
J. lax and indifferent toward



Kevin and his parents believed that his constitutional
rights had been violated. ³³ The United States District
³³

Court of New Hampshire; agreed to hear Kevin's case.
³⁴
His claim was based on the notion of personal liberty—the
right of every individual to the control of his or her own
person—protected by the Constitution's Fourteenth
Amendment. The court agreed with Kevin that a person's
right for wearing clothing of his or her own choosing is,
³⁵
in fact, protected by the Fourteenth Amendment.

The court noted, however that restrictions may be justified
³⁶
in some circumstances, such as in the school setting.

So did Kevin have a right to wear blue jeans to
school? The court determined that the school board had
failed to show that wearing jeans actually inhibited the
educational process, which is guided by authority figures.
³⁷

Furthermore, the board offered no evidence to back up it's
³⁸

claim that such clothing created a negative educational
³⁹
environment. Certainly the school board would
be justified in prohibiting students from wearing
clothing that was unsanitary, revealing, or obscene.

33. Given that all of the choices are true, which one would most effectively introduce the main idea of this paragraph?
- A. NO CHANGE
B. The principal said dungarees and blue jeans were the same thing, so Kevin should have known better.
C. If Kevin's jeans had been dirty and torn, the principal might have been justified in expelling him.
D. These events occurred in a time of social unrest, and emotions were running high.
34. F. NO CHANGE
G. Court, of New Hampshire
H. Court of New Hampshire
J. Court of New Hampshire,
35. A. NO CHANGE
B. of wearing
C. to wear
D. wearing
36. F. NO CHANGE
G. court noted, however,
H. court, noted however,
J. court noted however,
37. A. NO CHANGE
B. process, which has undergone changes since the 1970s.
C. process, a process we all know well.
D. process.
38. F. NO CHANGE
G. they're
H. its
J. ones
39. A. NO CHANGE
B. where
C. which
D. in which



The court remained unconvinced, therefore, that

40

when wearing jeans would actually impair the learning
process of Kevin or of his fellow classmates.

41

Kevin Bannister's case was significant in that it
was the first in the United States to address clothing
prohibitions of a school dress code. His challenge

42

initiated a review, of students' rights and administrative

43

responsibility in public education.

44

40. F. NO CHANGE
G. thus,
H. moreover,
J. however,

41. A. NO CHANGE
B. by wearing
C. wearing
D. having worn

42. Which choice would most effectively open this paragraph and convey the importance of this case?
F. NO CHANGE
G. Therefore, Kevin's case reminds us that you should stand up for your rights, no matter how old you are.
H. The case for personal liberty means the right to speak up must be taken seriously by the courts.
J. All in all, clothing is an important part of our identity.

43. A. NO CHANGE
B. review, of students' rights,
C. review of students' rights
D. review of students' rights,

44. F. NO CHANGE
G. on
H. with
J. about

Question 45 asks about the preceding passage as a whole.

45. Suppose the writer's goal had been to write a brief persuasive essay urging students to exercise their constitutional rights. Would this essay fulfill that goal?
A. Yes, because the essay focuses on how Kevin encouraged other students to exercise their constitutional rights.
B. Yes, because the essay focuses on various types of clothing historically worn by students as a freedom of expression.
C. No, because the essay suggests that the right to wear blue jeans was not a substantial constitutional right in the 1970s.
D. No, because the essay objectively reports on one case of a student exercising a particular constitutional right.

PASSAGE IV

The Case of the Trick Photographs

You might think that Sir Arthur Conan Doyle, the writer who invented Sherlock Holmes, the most logical of detectives, would have harbored strictly logical beliefs himself. But the author entertained a variety of fanciful ideas, including a belief in the mythical beings known as fairies. Since that belief, he was fooled in 1920 by two

46

schoolgirl cousins. 47

One day, Elsie Wright and Frances Griffiths returned from a walk in the English countryside with news that they had seen fairies. They had even taken photographs that showed several of the tiny sprites, some dancing in a ring in the grass, some fluttering in front of the girl's faces.

48

Many people were excited when they heard about

this seemingly true and factual proof of the existence of fairies, but Conan Doyle was more excited than most.

49

To make sure that he wasn't being deceived, Conan Doyle had the original photographic plates examined by experts, however, they found no evidence of double exposures. He then wrote an enthusiastic article

50

for *Strand* magazine, being the place in which most of his Sherlock Holmes stories had first appeared, and later wrote a book on the subject titled *The Coming of the Fairies.*

51

46. F. NO CHANGE
G. Because of
H. Concerning
J. For
47. If the writer were to delete the opening sentence of this paragraph (beginning the essay with "Sir Arthur Conan Doyle entertained a variety of fanciful..."), the essay would primarily lose:
A. information that sets up a contrast that follows.
B. an irrelevant but humorous digression.
C. information that explains Doyle's motivations.
D. an important description of the setting.
48. F. NO CHANGE
G. girls' faces.
H. girls faces.
J. girls face's.
49. A. NO CHANGE
B. this seemingly evident but apparent
C. what seemed to be an apparent
D. this apparent
50. F. NO CHANGE
G. who
H. which
J. they
51. A. NO CHANGE
B. in which the magazine where
C. in which
D. being where



Conan Doyle sent a copy of one of the photographs to his friend Harry Houdini, the famous magician and escape artist. Houdini, who devoted considerable effort to exposing hoaxes involving spiritualism and was

52

skeptical about the existence of supernatural beings. 53

When Houdini remained unconvinced by the evidence, Conan Doyle became angry. Though the two

remained cordial, but their friendship was damaged

54

due to the fact that they had the disagreement.

55

Some sixty years later, an elderly Frances Griffiths

56

publicly admitted that her and her cousin had staged the photographs as a practical joke. Shortly after her revelation, computer enhancement revealed the hatpins that were used to prop up the cardboard-cutout fairies.

58

Scientific analysis, since photography was a new art, finally closed the Case of the Trick Photographs.

59

52. F. NO CHANGE
 G. spiritualism, being
 H. spiritualism, was
 J. spiritualism and
53. If the writer were to delete the preceding sentence, the paragraph would primarily lose:
 A. details that provide an explanation for the friendship between Conan Doyle and Houdini.
 B. information that helps set the stage for what happens next in the essay.
 C. a description of the reasons behind Houdini's skepticism about the supernatural.
 D. nothing at all, since this sentence provides irrelevant information.
54. F. NO CHANGE
 G. cordial and
 H. cordial that
 J. cordial,
55. A. NO CHANGE
 B. because of the fact that they had a
 C. due to the fact of their
 D. by the
56. F. NO CHANGE
 G. (Do NOT begin new paragraph) After some
 H. (Begin new paragraph) Since some
 J. (Begin new paragraph) Some
57. A. NO CHANGE
 B. her cousin and herself
 C. she and her cousin
 D. her cousin and her
58. Which of the following alternatives to the underlined portion would NOT be acceptable?
 F. that had been used
 G. the girls used
 H. using
 J. used
59. Which choice would best tie the conclusion of this essay to its opening sentence?
 A. NO CHANGE
 B. of the kind a modern-day Sherlock Holmes might use,
 C. which the great Houdini himself would have appreciated,
 D. a methodology that was still in its infancy,



Question 60 asks about the preceding passage as a whole.

60. Suppose the writer had decided to write an essay that summarizes how beliefs in the supernatural have influenced the writing of famous authors. Would this essay fulfill the writer's goal?
- F. Yes, because the essay makes the point that Conan Doyle's belief in fairies clearly influenced his Sherlock Holmes stories.
 - G. Yes, because the essay indicates that Conan Doyle's disagreement with Houdini motivated him to write about the supernatural.
 - H. No, because the essay argues that the author's belief in fairies and the supernatural did not in any way affect his writing.
 - J. No, because the essay limits its focus to the particular events surrounding one author's reaction to evidence of the supernatural.

PASSAGE V

Her Letters to the World

Emily Dickinson, one of America's great nineteenth-century poets, was a prolific letter writer. Although her physical contact with the world was limited by caring for her invalid mother and by her own poor health, whose correspondence was

61

extensive: over one thousand letters to upwards of one hundred correspondents. These letters provide insight into her daily life and her poetry.

62

Dickinson's lifetime of letters range from playful to serious. As a young woman she wrote, of pining for a

63

valentine and of visiting the Chinese Museum in Boston. Her letters in later years reveal that she missed friends and

64

- 61. A. NO CHANGE
B. their
C. Dickinson's
D. who's
- 62. F. NO CHANGE
G. extensive, and over
H. extensive; over
J. extensive. Over
- 63. A. NO CHANGE
B. (Do NOT begin new paragraph) As a young woman, she wrote
C. (Begin new paragraph) As a young woman, she wrote,
D. (Begin new paragraph) As a young woman, she wrote
- 64. F. NO CHANGE
G. visiting to
H. of her visiting to
J. of her visiting at

encouraged them to visit. Dickinson stayed in contact with correspondents for many years. In a teasing letter to her brother, she bemoaned the fact that a big barn fire couldn't have waited until he returned to see it, since he "enjoyed

such things so much." Other letters are solemn; speaking

of relatives and friends whom had died.

Perhaps the correspondent who came to know Dickinson best through their thirty-six-year exchange of letters was Emily's friend, sister-in-law, and neighbor, Susan Gilbert Dickinson. Susan was a spiritual, social, and intellectual companion for Emily. In fact, in one letter, Emily stated that Shakespeare was the only person who had taught her more than Susan had.

One significant aspect of this relationship was: that Susan was perhaps the only reader of Emily's poems-in-progress. Letters between the two suggest that Susan might frequently have given feedback on her work, including some of her most famous

poems, composed at her home in Amherst, Massachusetts.

At one point, Emily sent a draft of her poem "Safe in Their

Alabaster Chambers" to Susan, who read the poem. As

65. Given that all of the choices are true, which one best develops the paragraph's focus on the roles that letters played in Emily Dickinson's life?

- A. NO CHANGE
- B. Her personal interests also included keen observation of the natural world around her.
- C. Though she produced volumes of letters, none were shared publicly until after her death.
- D. She enjoyed hearing their news and reflecting with them on political events.

66. F. NO CHANGE
G. solemn they speak
H. solemn, speaking
J. solemn. Speaking

67. A. NO CHANGE
B. who
C. who they
D. of whom

68. F. NO CHANGE
G. was that Susan
H. was, that Susan
J. was that Susan,

69. A. NO CHANGE
B. her feedback on Emily's
C. Emily feedback on her
D. her feedback on her

70. F. NO CHANGE
G. poems, which varied in form, style, and line length.
H. poems, most without obvious rhyme.
J. poems.

71. Given that all the choices are true, which one would most clearly describe an interaction between Susan and Emily during Emily's writing process?

- A. NO CHANGE
- B. liked the poem tremendously.
- C. considered and thought about the poem.
- D. praised the poem but suggested revisions.



a result, Emily wrote two other versions of the second stanza.

72

Dickinson's last twenty years of letters—many over 1,500 words in length—reveals the breadth and depth of

73

one's connection to the world through a wide circle of

74

correspondents. Perhaps, this legacy of letters, explains what she meant when she said that her friends were her “estate.”

75

72. F. NO CHANGE
 G. rewrote two other alternate
 H. rewrote two additional alternate
 J. wrote two alternate revised

73. A. NO CHANGE
 B. reveal
 C. will of revealed
 D. would of revealed

74. F. NO CHANGE
 G. people's
 H. her
 J. their

75. A. NO CHANGE
 B. Perhaps this, legacy of letters,
 C. Perhaps this legacy of letters,
 D. Perhaps this legacy of letters

END OF TEST 1

STOP! DO NOT TURN THE PAGE UNTIL TOLD TO DO SO.



MATHEMATICS TEST

60 Minutes—60 Questions

DIRECTIONS: Solve each problem, choose the correct answer, and then fill in the corresponding oval on your answer document.

Do not linger over problems that take too much time. Solve as many as you can; then return to the others in the time you have left for this test.

You are permitted to use a calculator on this test. You may use your calculator for any problems you choose,

but some of the problems may best be done without using a calculator.

Note: Unless otherwise stated, all of the following should be assumed.

1. Illustrative figures are NOT necessarily drawn to scale.
2. Geometric figures lie in a plane.
3. The word *line* indicates a straight line.
4. The word *average* indicates arithmetic mean.

1. Two enterprising college students decide to start a business. They will make up and deliver helium balloon bouquets for special occasions. It will cost them \$39.99 to buy a machine to fill the balloons with helium. They estimate that it will cost them \$2.00 to buy the balloons, helium, and ribbons needed to make each balloon bouquet. Which of the following expressions could be used to model the total cost for producing b balloon bouquets?
 - A. $\$ 2.00b + \39.99
 - B. $\$37.99b$
 - C. $\$39.99b + \$ 2.00$
 - D. $\$41.99b$
 - E. $\$79.98b$
2. What is the value of the expression $(x - y)^2$ when $x = 5$ and $y = -1$?
 - F. 4
 - G. 6
 - H. 16
 - J. 24
 - K. 36
3. On the first day of school, Mr. Vilani gave his third-grade students 5 new words to spell. On each day of school after that, he gave the students 3 new words to spell. In the first 20 days of school, how many new words had he given the students to spell?
 - A. 28
 - B. 62
 - C. 65
 - D. 68
 - E. 152
4. Which of the following is equivalent to $(4x^2)^3$?
 - F. $64x^8$
 - G. $64x^6$
 - H. $12x^6$
 - J. $12x^5$
 - K. $4x^6$
5. Which of the following lists all the positive factors of 8?
 - A. 1, 8
 - B. 2, 4
 - C. 2, 4, 6
 - D. 8, 16, 32
 - E. 1, 2, 4, 8
6. Which of the following is an equivalent simplified expression for $2(4x + 7) - 3(2x - 4)$?
 - F. $x + 2$
 - G. $2x + 2$
 - H. $2x + 26$
 - J. $3x + 10$
 - K. $3x + 11$
7. To determine a student's overall test score for the semester, Ms. Lopez throws out the lowest test score and takes the average of the remaining test scores. Victor earned the following test scores in Ms. Lopez's class this semester: 62, 78, 83, 84, and 93. What overall test score did Victor earn in Ms. Lopez's class this semester?
 - A. 67.6
 - B. 80.0
 - C. 83.0
 - D. 83.5
 - E. 84.5
8. Uptown Cable, a cable TV provider, charges each customer \$120 for installation, plus \$25 per month for cable programming. Uptown's competitor, Downtown Cable, charges each customer \$60 for installation, plus \$35 per month for cable programming. A customer who signs up with Uptown will pay the same total amount for cable TV as a customer who signs up with Downtown if each pays for installation and cable programming for how many months?
 - F. 3
 - G. 6
 - H. 10
 - J. 18
 - K. 30



9. In the 8-sided figure below, adjacent sides meet at right angles and the lengths given are in meters. What is the perimeter of the figure, in meters?

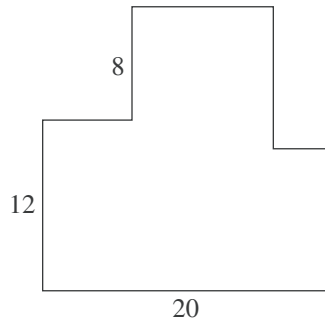

- A. 40
B. 80
C. 120
D. 160
E. 400
10. The sum of the real numbers x and y is 11. Their difference is 5. What is the value of xy ?

- F. 3
G. 5
H. 8
J. 24
K. 55

11. For all x , $(3x + 7)^2 = ?$

- A. $6x + 14$
B. $6x^2 + 14$
C. $9x^2 + 49$
D. $9x^2 + 21x + 49$
E. $9x^2 + 42x + 49$

12. What is the slope of the line through $(-5, 2)$ and $(6, 7)$ in the standard (x, y) coordinate plane?

- F. 9
G. 5
H. -5
J. $\frac{5}{11}$
K. $-\frac{5}{11}$

13. When $\frac{1}{3}k + \frac{1}{4}k = 1$, what is the value of k ?

- A. $\frac{1}{7}$
B. $\frac{12}{7}$
C. $\frac{7}{2}$
D. 6
E. 12

14. What is the length, in feet, of the hypotenuse of a right triangle with legs that are 6 feet long and 7 feet long, respectively?

- F. $\sqrt{13}$
G. $\sqrt{85}$
H. 13
J. 21
K. 42

15. Hexagon $ABCDEF$ shown below was drawn on a grid with unit squares. Each vertex is at the intersection of 2 grid lines. What is the area of the hexagon, in square units?

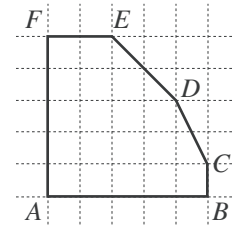

- A. 18
B. 19
C. 20
D. 22
E. 25

16. In the figure below, \overline{AD} is perpendicular to \overline{BD} , \overline{AC} is perpendicular to \overline{BC} , and $AD \cong BC$. Which of the following congruences is NOT necessarily true?

- F. $\overline{AC} \cong \overline{BD}$
G. $\overline{AD} \cong \overline{AE}$
H. $\overline{AE} \cong \overline{BE}$
J. $\angle DAB \cong \angle CBA$
K. $\angle EAB \cong \angle EBA$

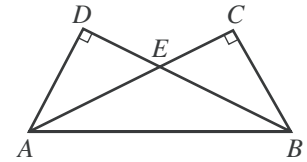

17. Leticia went into Discount Music to price CDs. All CDs were discounted 23% off the marked price. Leticia wanted to program her calculator so she could input the marked price and the discounted price would be the output. Which of the following is an expression for the discounted price on a marked price of p dollars?

- A. $p - 0.23p$
B. $p - 0.23$
C. $p - 23p$
D. $p - 23$
E. $0.23p$

18. In the figure below, A , D , B , and G are collinear. If $\angle CAD$ measures 76° , $\angle BCD$ measures 47° , and $\angle CBG$ measures 140° , what is the degree measure of $\angle ACD$?

- F. 12°
G. 14°
H. 17°
J. 36°
K. 43°

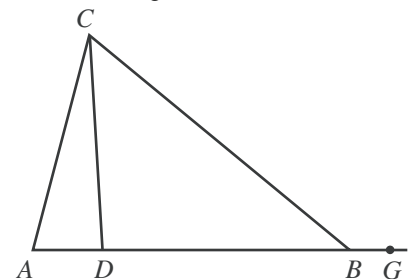



19. Ms. Lewis plans to drive 900 miles to her vacation destination, driving an average of 50 miles per hour. How many miles per hour faster must she average, while driving, to reduce her total driving time by 3 hours?

A. 5
B. 8
C. 10
D. 15
E. 18

20. For all positive integers x , what is the greatest common factor of the 2 numbers $216x$ and $180x$?

F. 6
G. 72
H. x
J. $12x$
K. $36x$

21. The table below shows the price of different quantities of standard-sized lemons at Joe's Fruit Stand. What is the least amount of money needed to purchase exactly 20 standard-sized lemons if the bags must be sold intact and there is no tax charged for lemons?

Number of lemons:	1	bag of 6	bag of 12
Total price:	\$0.30	\$1.20	\$2.10

A. \$3.60
B. \$3.90
C. \$4.20
D. \$4.50
E. \$6.00

22. The diameter, d centimeters, of the metal poles Goodpole Manufacturing produces must satisfy the inequality $|d - 3| \leq 0.001$. What is the maximum diameter, in centimeters, such a metal pole may have?

F. 1.4995
G. 1.5005
H. 2.999
J. 3.000
K. 3.001

23. Which of the following is a factored form of the expression $5x^2 - 13x - 6$?

A. $(x - 3)(5x + 2)$
B. $(x - 2)(5x - 3)$
C. $(x - 2)(5x + 3)$
D. $(x + 2)(5x - 3)$
E. $(x + 3)(5x - 2)$

24. A bag contains 6 red marbles, 5 yellow marbles, and 7 green marbles. How many additional red marbles must be added to the 18 marbles already in the bag so that the probability of randomly drawing a red marble is $\frac{3}{5}$?

F. 12
G. 16
H. 18
J. 24
K. 36

25. Which of the following trigonometric equations is valid for the side measurement x inches, diagonal measurement y inches, and angle measurement w° in the rectangle shown below?

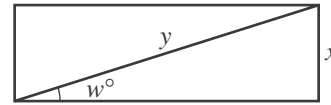

A. $\cos w^\circ = \frac{x}{y}$
B. $\cot w^\circ = \frac{x}{y}$
C. $\sec w^\circ = \frac{x}{y}$
D. $\sin w^\circ = \frac{x}{y}$
E. $\tan w^\circ = \frac{x}{y}$

26. The slope of the line with equation $y = ax + b$ is greater than the slope of the line with equation $y = cx + b$. Which of the following statements *must* be true about the relationship between a and c ?

F. $a \leq c$
G. $a < c$
H. $a = c$
J. $a > c$
K. $a \geq c + 1$

27. Minh cuts a board in the shape of a regular hexagon and pounds in a nail at an equal distance from each vertex, as shown in the figure below. How many rubber bands will she need in order to stretch a different rubber band across every possible pair of nails?

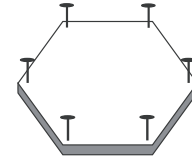

A. 15
B. 14
C. 12
D. 9
E. 6

28. There are 280 runners registered for a race, and the runners are divided into 4 age categories, as shown in the table below.

Age category:	under 16	16–25	26–35	over 35
Number of runners:	40	76	112	52

The prize committee has 60 prizes to award and wants the prizes to be awarded in proportion to the number of runners registered in each category. How many prizes should be designated for the 26–35 age category?

F. 15
G. 17
H. 24
J. 36
K. 40



Use the following information to answer questions 29–32.

The youth center has installed a swimming pool on level ground. The pool is a right circular cylinder with a diameter of 24 feet and a height of 6 feet. A diagram of the pool and its entry ladder is shown below.

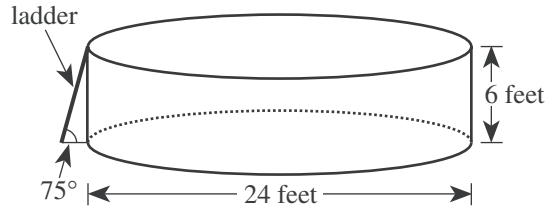

29. To the nearest cubic foot, what is the volume of water that will be in the pool when it is filled with water to a depth of 5 feet?

(Note: The volume of a cylinder is given by $\pi r^2 h$, where r is the radius and h is the height.)

- A. 942
 B. 1,885
 C. 2,262
 D. 9,047
 E. 11,310

30. A plastic cover is made for the pool. The cover will rest on the top of the pool and will include a wedge-shaped flap that forms a 45° angle at the center of the cover, as shown in the figure below. A zipper will go along 1 side of the wedge-shaped flap and around the arc. Which of the following is closest to the length, in feet, of the zipper?

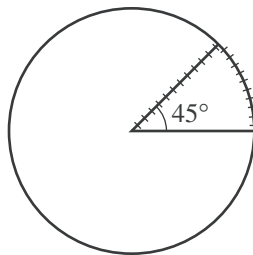

- F. 17
 G. 22
 H. 24
 J. 29
 K. 57

31. Two hoses are used to fill the pool. Twice as many gallons of water per minute flow through one of the hoses as through the other. Both hoses had been on for 12 hours and had filled the pool to the 4-foot mark when the hose with the faster flow stopped working. The hose with the slower flow then finished filling the pool to the 5-foot mark. Which of the following graphs shows the relationship between the time spent filling the pool and the height of the water in the pool?

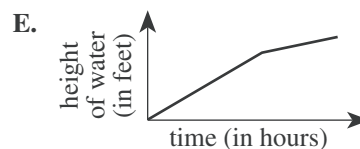
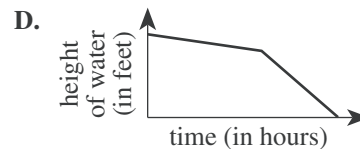
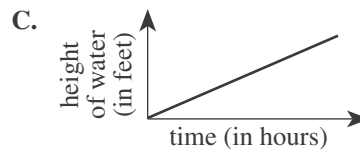
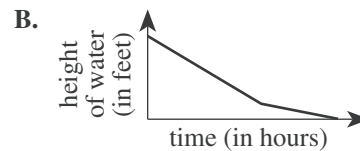
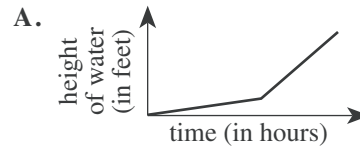

32. The directions for assembling the pool state that the ladder should be placed at an angle of 75° relative to level ground. Which of the following expressions involving tangent gives the distance, in feet, that the bottom of the ladder should be placed away from the bottom edge of the pool in order to comply with the directions?

F. $\frac{6}{\tan 75^\circ}$

G. $\frac{\tan 75^\circ}{6}$

H. $\frac{1}{6 \tan 75^\circ}$

J. $6 \tan 75^\circ$

K. $\tan(6 \cdot 75^\circ)$



33. For a population that grows at a constant rate of $r\%$ per year, the formula $P(t) = p_0\left(1 + \frac{r}{100}\right)^t$ models the population t years after an initial population of p_0 people is counted.

The population of the city of San Jose was 782,000 in 1990. Assume the population grows at a constant rate of 5% per year. According to this formula, which of the following is an expression for the population of San Jose in the year 2000 ?

- A. $782,000(6)^{10}$
 B. $782,000(1.5)^{10}$
 C. $782,000(1.05)^{10}$
 D. $(782,000 \times 1.5)^{10}$
 E. $(782,000 \times 1.05)^{10}$
34. Tom's long-distance service charges \$0.10 per minute from 7:00 P.M. to 7:00 A.M. on weekdays, all day on Saturdays, and all day on holidays; \$0.05 per minute all day on Sundays; and \$0.25 per minute at all other times. The table below gives his long-distance calls for 1 week, including the date and day of each call, the time it was placed, and the number of minutes it lasted.

Date and day	Time	Number of minutes
11/22 Tuesday	5:00 P.M.	8
11/23 Wednesday	10:30 A.M.	10
11/24 Thursday Thanksgiving holiday	11:30 A.M.	15
11/26 Saturday	9:30 A.M.	17
11/27 Sunday	12:15 P.M.	22

What did Tom's long-distance service charge him for the calls in the table?

- F. \$7.30
 G. \$7.60
 H. \$7.95
 J. \$8.80
 K. \$9.90
35. The parallel sides of the isosceles trapezoid shown below are 10 feet long and 16 feet long, respectively. What is the distance, in feet, between these 2 sides?

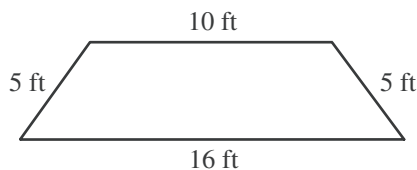

- A. 3
 B. 4
 C. 5
 D. 10
 E. 16

36. The inequality $3(x + 2) > 4(x - 3)$ is equivalent to which of the following inequalities?

- F. $x < -6$
 G. $x < 5$
 H. $x < 9$
 J. $x < 14$
 K. $x < 18$

37. In the standard (x,y) coordinate plane, the midpoint of \overline{AB} is $(4,-3)$ and A is located at $(1,-5)$. If (x,y) are the coordinates of B , what is the value of $x + y$?

- A. 19
 B. 8
 C. 6
 D. -1.5
 E. -3

38. For all x in the domain of the function $\frac{x+1}{x^3-x}$, this function is equivalent to:

- F. $\frac{1}{x^2} - \frac{1}{x^3}$
 G. $\frac{1}{x^3} - \frac{1}{x}$
 H. $\frac{1}{x^2-1}$
 J. $\frac{1}{x^2-x}$
 K. $\frac{1}{x^3}$

39. In the figure below, line l is parallel to line m . Transversals t and u intersect at point A on l and intersect m at points C and B , respectively. Point X is on m , the measure of $\angle ACX$ is 130° , and the measure of $\angle BAC$ is 80° . How many of the angles formed by rays of l , m , t , and u have measure 50° ?

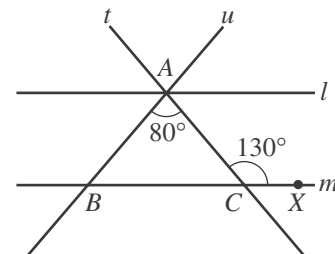

- A. 4
 B. 6
 C. 8
 D. 10
 E. 12

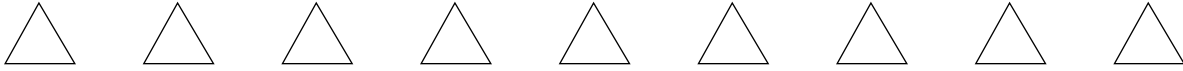

40. Tickets for the Senior Talent Show at George Washington Carver High School are \$3 for adults and \$2 for students. To cover expenses, a total of \$600 must be collected from ticket sales for the show. One of the following graphs in the standard (x,y) coordinate plane, where x is the number of adult tickets sold and y is the number of student tickets sold, represents all the possible combinations of ticket sales that cover at least \$600 in expenses. Which graph is it?

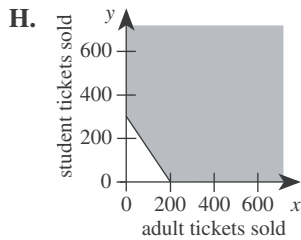
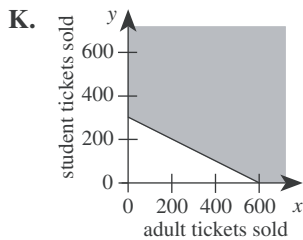
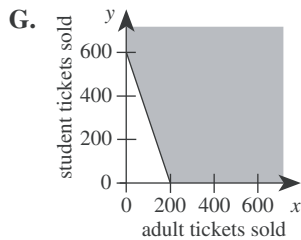
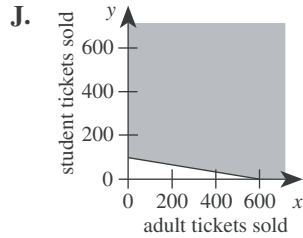
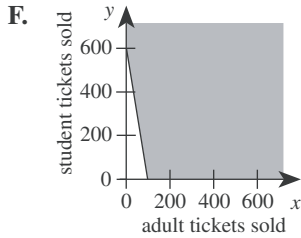

41. What is the median of the following 7 scores?

42, 67, 33, 79, 33, 89, 21

- A. 42
- B. 52
- C. 54.5
- D. 56
- E. 79

42. What are the real solutions to the equation $|x|^2 + 2|x| - 3 = 0$?

- F. ± 1
- G. ± 3
- H. 1 and 3
- J. -1 and -3
- K. ± 1 and ± 3

43. The point $(2,5)$ is shown in the standard (x,y) coordinate plane below. Which of the following is another point on the line through the point $(2,5)$ with a slope of $-\frac{2}{3}$?

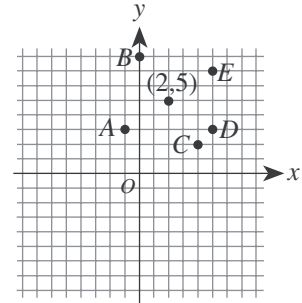

- A. $A(-1,3)$
- B. $B(0,8)$
- C. $C(4,2)$
- D. $D(5,3)$
- E. $E(5,7)$

44. For the triangles in the figure below, which of the following ratios of side lengths is equivalent to the ratio of the perimeter of $\triangle ABC$ to the perimeter of $\triangle DAB$?

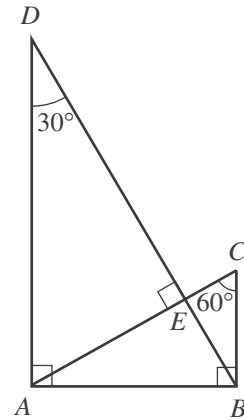

- F. $AB:AD$
- G. $AB:BD$
- H. $AD:BD$
- J. $BC:AD$
- K. $BC:BD$

45. In the figure below, 2 nonadjacent sides of a regular pentagon (5 congruent sides and 5 congruent interior angles) are extended until they meet at point X. What is the measure of $\angle X$?

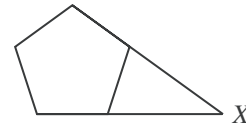

- A. 18°
- B. 30°
- C. 36°
- D. 45°
- E. 72°

46. The edges of a cube are each 3 inches long. What is the surface area, in square inches, of this cube?

- F. 9
- G. 18
- H. 27
- J. 36
- K. 54

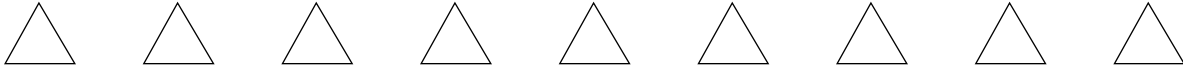

47. A number is increased by 25% and the resulting number is then decreased by 20%. The final number is what percent of the original number?
- A. 90%
 B. 95%
 C. 100%
 D. 105%
 E. 120%
48. Two numbers are *reciprocals* if their product is equal to 1. If x and y are reciprocals and $x > 1$, then y must be:
- F. less than -1 .
 G. between 0 and -1 .
 H. equal to 0.
 J. between 0 and 1.
 K. greater than 1.
49. The number line graph below is the graph of which of the following inequalities?



- A. $-1 \leq x$ and $3 \leq x$
 B. $-1 \leq x$ and $3 \geq x$
 C. $-1 \leq x$ or $3 \leq x$
 D. $-1 \geq x$ or $3 \leq x$
 E. $-1 \geq x$ or $3 \geq x$
50. All of the following graphs have equal scales on the axes. One of the graphs shows only points for which the y -coordinate is 1 less than the square of the x -coordinate. Which one?

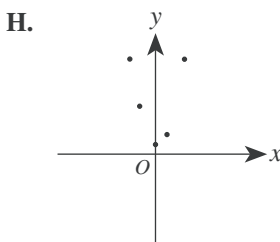
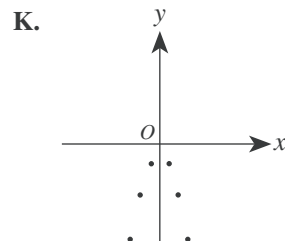
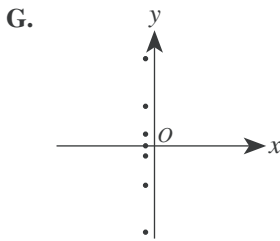
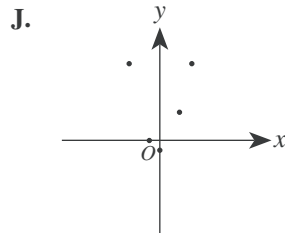
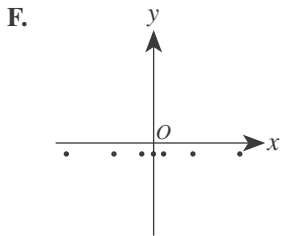

51. In teaching a lesson on the concept of thirds, Ms. Chu uses a divide-and-set-aside procedure. She starts with a certain number of colored disks, divides them into 3 equal groups, and sets 1 group aside to illustrate $\frac{1}{3}$. She repeats the procedure by taking the disks she had NOT set aside, dividing them into 3 equal groups, and setting 1 of these groups aside. If Ms. Chu wants to be able to complete the divide-and-set-aside procedure at least 4 times (without breaking any of the disks into pieces), which of the following is the minimum number of colored disks she can start with?
- A. 12
 B. 15
 C. 27
 D. 54
 E. 81

52. Which of the following is true for all consecutive integers m and n such that $m < n$?
- F. m is odd
 G. n is odd
 H. $n - m$ is even
 J. $n^2 - m^2$ is odd
 K. $m^2 + n^2$ is even

53. A function P is defined as follows:

$$\begin{aligned} \text{for } x > 0, P(x) &= x^5 + x^4 - 36x - 36 \\ \text{for } x < 0, P(x) &= -x^5 + x^4 + 36x - 36 \end{aligned}$$

What is the value of $P(-1)$?

- A. -70
 B. -36
 C. 0
 D. 36
 E. 70
54. For a project in Home Economics class, Kirk is making a tablecloth for a circular table 3 feet in diameter. The finished tablecloth needs to hang down 5 inches over the edge of the table all the way around. To finish the edge of the tablecloth, Kirk will fold under and sew down 1 inch of the material all around the edge. Kirk is going to use a single piece of rectangular fabric that is 60 inches wide. What is the shortest length of fabric, in inches, Kirk could use to make the tablecloth without putting any separate pieces of fabric together?
- F. 15
 G. 24
 H. 30
 J. 42
 K. 48



55. The equations of the 2 graphs shown below are $y_1(t) = a_1 \sin(b_1 t)$ and $y_2(t) = a_2 \cos(b_2 t)$, where the constants b_1 and b_2 are both positive real numbers.

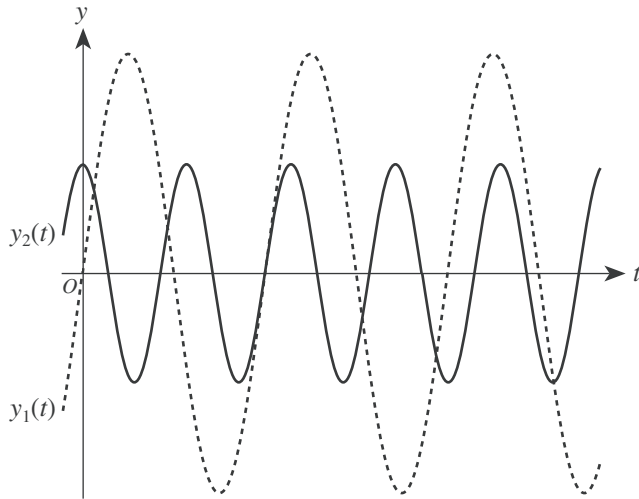

Which of the following statements is true of the constants a_1 and a_2 ?

- A. $0 < a_1 < a_2$
 B. $0 < a_2 < a_1$
 C. $a_1 < 0 < a_2$
 D. $a_1 < a_2 < 0$
 E. $a_2 < a_1 < 0$
56. For x such that $0 < x < \frac{\pi}{2}$, the expression $\frac{\sqrt{1 - \cos^2 x}}{\sin x} + \frac{\sqrt{1 - \sin^2 x}}{\cos x}$ is equivalent to:
- F. 0
 G. 1
 H. 2
 J. $-\tan x$
 K. $\sin 2x$
57. Consider the functions $f(x) = \sqrt{x}$ and $g(x) = 7x + b$. In the standard (x,y) coordinate plane, $y = f(g(x))$ passes through $(4,6)$. What is the value of b ?
- A. 8
 B. -8
 C. -25
 D. -26
 E. $4 - 7\sqrt{6}$

58. The triangle, $\triangle XYZ$, that is shown below has side lengths of x , y , and z inches and is not a right triangle. Let X' be the image of X when the triangle is reflected across \overline{YZ} . Which of the following is an expression for the perimeter, in inches, of quadrilateral $X'YZX$?

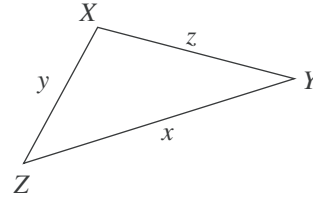

- F. $2(y + z) + x$
 G. $2(x + y + z)$
 H. $2(x + y)$
 J. $2(x + z)$
 K. $2(y + z)$
59. A function f is an *odd* function if and only if $f(-x) = -f(x)$ for every value of x in the domain of f . One of the functions graphed in the standard (x,y) coordinate plane below is an odd function. Which one?

A.

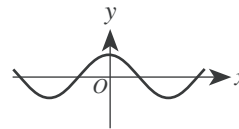

D.

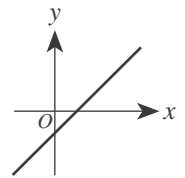

B.

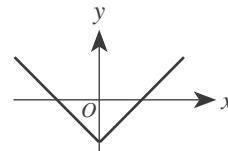

E.

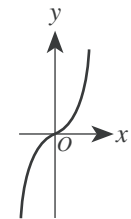

C.

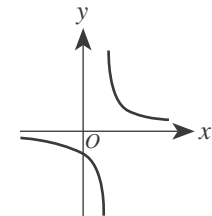

60. What is the real value of x in the equation $\log_2 24 - \log_2 3 = \log_5 x$?
- F. 3
 G. 21
 H. 72
 J. 125
 K. 243

END OF TEST 2

STOP! DO NOT TURN THE PAGE UNTIL TOLD TO DO SO.

DO NOT RETURN TO THE PREVIOUS TEST.

READING TEST

35 Minutes—40 Questions

DIRECTIONS: There are four passages in this test. Each passage is followed by several questions. After reading a passage, choose the best answer to each question and fill in the corresponding oval on your answer document. You may refer to the passages as often as necessary.

Passage I

PROSE FICTION: This passage is adapted from the short story “American History” by Judith Ortiz-Cofer (©1992 by Judith Ortiz-Cofer). The story appeared in the anthology *Iguana Dreams: New Latino Fiction*.

There was only one source of beauty and light for me my ninth grade year. The only thing I had anticipated at the start of the semester. That was seeing Eugene. In August, Eugene and his family had moved
5 into the only house on the block that had a yard and trees. I could see his place from my bedroom window in El Building. In fact, if I sat on the fire escape I was literally suspended above Eugene’s backyard. It was my favorite spot to read my library books in the summer.
10 Until that August the house had been occupied by an old couple. Over the years I had become part of their family, without their knowing it, of course. I had a view of their kitchen and their backyard, and though I could not hear what they said, I knew when they were arguing,
15 when one of them was sick, and many other things. I knew all this by watching them at mealtimes. I could see their kitchen table, the sink, and the stove. During good times, he sat at the table and read his newspapers while she fixed the meals. If they argued, he would leave and
20 the old woman would sit and stare at nothing for a long time. When one of them was sick, the other would come and get things from the kitchen and carry them out on a tray. The old man had died in June. The house had stood empty for weeks. I had had to resist the temptation to
25 climb down into the yard and water the flowers the old lady had taken such good care of.

By the time Eugene’s family moved in, the yard was a tangled mass of weeds. The father had spent several days mowing, and when he finished, from where I sat, I didn’t see the red, yellow, and purple clusters that meant flowers to me. I didn’t see this family sit down at the kitchen table together. It was just the mother, a red-headed tall woman who wore a white uniform; the father was gone before I got up in the morning and was
35 never there at dinner time. I only saw him on weekends when they sometimes sat on lawn-chairs under the oak tree, each hidden behind a section of the newspaper; and there was Eugene. He was tall and blond, and he wore glasses. I liked him right away because he sat at the kitchen table and read books for hours. That
40 summer, before we had even spoken one word to each other, I kept him company on my fire escape.

Once school started I looked for him in all my classes, but P. S. 13 was a huge place and it took me
45 days and many discreet questions to discover Eugene. After much maneuvering I managed “to run into him” in the hallway where his locker was—on the other side of the building from mine—and in study hall at the library where he first seemed to notice me, but did not
50 speak; and finally, on the way home after school one day when I decided to approach him directly, though my stomach was doing somersaults.

I was ready for rejection, snobbery, the worst. But when I came up to him and blurted out: “You’re
55 Eugene. Right?” he smiled, pushed his glasses up on his nose, and nodded. I saw then that he was blushing deeply. Eugene liked me, but he was shy. I did most of the talking that day. He nodded and smiled a lot. In the weeks that followed, we walked home together. He
60 would linger at the corner of El Building for a few minutes then walk down to his house.

I did not tell Eugene that I could see inside his kitchen from my bedroom. I felt dishonest, but I liked my secret sharing of his evenings, especially now that I
65 knew what he was reading since we chose our books together at the school library.

I also knew my mother was unhappy in Paterson, New Jersey, but my father had a good job at the blue-jeans factory in Passaic and soon, he kept assuring us,
70 we would be moving to our own house there. I had learned to listen to my parents’ dreams, which were spoken in Spanish, as fairy tales, like the stories about life in Puerto Rico before I was born. I had been to the island once as a little girl. We had not been back there
75 since then, though my parents talked constantly about buying a house on the beach someday, retiring on the island—that was a common topic among the residents of El Building. As for me, I was going to go to college and become a teacher.

But after meeting Eugene I began to think of the present more than of the future. What I wanted now was to enter that house I had watched for so many years. I wanted to see the other rooms where the old people had lived, and where the boy spent his time. Most of all, I
85 wanted to sit at the kitchen table with Eugene like two adults, like the old man and his wife had done, maybe drink some coffee and talk about books.

1. The main theme of this passage concerns the:
 - A. difficulty of first starting and then maintaining a friendship.
 - B. process of making a new friend and how the friendship changes the narrator.
 - C. problems the narrator has dealing with the loss of her former neighbors.
 - D. differences in the lives led by two pairs of adults who at different times lived in the same house.
2. Which of the following questions is NOT answered by information in the passage?
 - F. Has the narrator ever walked around inside Eugene's house?
 - G. What hobby or interest do Eugene and the narrator share?
 - H. What makes Eugene's house different from other houses on the block?
 - J. What careers other than teaching has the narrator considered pursuing?
3. The narrator draws which of the following comparisons between the old couple and Eugene's parents?
 - A. The old couple were more socially outgoing and had many more friends than Eugene's parents.
 - B. Eugene's parents are just as interested in tending the lawn and flowers as the old couple were.
 - C. Eugene's parents are less nurturing of each other and spend less time together than the old couple did.
 - D. Just like the old man and old woman, both of Eugene's parents appear to have jobs outside the home.
4. In terms of developing the narrative, the last two paragraphs (lines 67–87) primarily serve to:
 - F. provide background details about the narrator and her family in order to highlight the narrator's unique and shifting perspective.
 - G. describe the narrator's family in order to establish a contrast between her parents and Eugene's parents.
 - H. portray the narrator's family in order to show how her friendship with Eugene affected the various members of her family.
 - J. depict the hopes and dreams of the narrator's parents in order to show how her parents' aspirations changed over time.
5. It can most reasonably be inferred from the passage that when the narrator says, "I didn't see the red, yellow, and purple clusters that meant flowers to me" (lines 30–31), she is most nearly indicating that:
 - A. from her current position, she couldn't see the old woman's flowers, which were still growing near the house.
 - B. the flowers grown by the old woman had died because the narrator had stopped watering them.
 - C. the flowers grown by the old woman had been cut down when Eugene's father mowed the lawn.
 - D. the weeds that had grown up in the old couple's lawn had intertwined with the flowers, making the flowers hard to see.
6. According to the narrator, which of the following statements was true about Eugene at the moment when she first talked to him?
 - F. Due to the size of the school, he had not even noticed the narrator until she started talking to him.
 - G. He had searched unsuccessfully for the narrator's locker several different times and had been too shy to ask someone where it was.
 - H. He had first noticed the narrator in study hall but had been uninterested in her until she introduced herself.
 - J. He had apparently taken notice of the narrator at school and had come to like her but felt nervous about introducing himself.
7. When the narrator says, "I began to think of the present more than of the future" (lines 80–81), she most likely means that meeting Eugene led her to:
 - A. shift some of her attention away from her career plans and onto the developing friendship.
 - B. think more about her own work interests than about the career her parents thought she should pursue.
 - C. put off her plans of returning to Puerto Rico for a visit in favor of continuing to prepare for college.
 - D. want to spend more time with him instead of helping her parents plan a vacation to Puerto Rico.
8. The narrator most nearly portrays her parents' dreams as:
 - F. close to being realized because of her father's good job.
 - G. somewhat uncommon among the other residents of the family's building.
 - H. ones she has heard about many times but that seem far off and remote to her.
 - J. ones she shares with her parents and longs to fulfill.
9. The narrator claims that she felt close to the old couple because she had:
 - A. listened in on so many of their conversations over the years.
 - B. helped take care of the old woman's flowers after the woman's husband had died.
 - C. been able to watch them as they moved through their entire house.
 - D. regularly observed them during their mealtimes.
10. Which of the following best describes the narrator's feelings about secretly observing Eugene at his home?
 - F. Joy tinged with suspicion
 - G. Enjoyment mixed with guilt
 - H. Happiness overwhelmed by a sense of betrayal
 - J. Pleasure lessened by having actually met him

Passage II

SOCIAL SCIENCE: This passage is adapted from volume 2 of Blanche Wiesen Cook's biography *Eleanor Roosevelt* (©1999 by Blanche Wiesen Cook).

Eleanor Roosevelt [ER] is the most controversial First Lady in United States history. Her journey to greatness, her voyage out beyond the confines of good wife and devoted mother, involved determination and
5 amazing courage. It also involved one of history's most unique partnerships. Franklin Delano Roosevelt [FDR] admired his wife, appreciated her strengths, and depended on her integrity.

However, ER and FDR had different priorities, occasionally competing goals, and often disagreed. In the White House they ran two distinct and separate courts.

By 1933 [her first year as First Lady], ER was an accomplished woman who had achieved several of her
15 life's goals. With her partners, ER was a businesswoman who co-owned the Val-Kill crafts factory, a political leader who edited and copublished the *Women's Democratic News*, and an educator who co-owned and taught at a New York school for girls.

As First Lady, Eleanor Roosevelt did things that had never been done before. She upset race traditions, championed a New Deal for women, and on certain issues actually ran a parallel administration. On housing and the creation of model communities, for
25 example, ER made decisions and engineered policy.

At the center of a network of influential women who ran the Women's Committee of the Democratic Party led by Molly Dewson, ER worked closely with the women who had dominated the nation's social reform struggles for decades. With FDR's election, the goals of the great progressive pioneers, Jane Addams, Florence Kelley, and Lillian Wald, were at last at the forefront of the country's agenda. ER's mentors since 1903, they had battled on the margins of national politics since the 1880s for public health, universal education, community centers, sanitation programs, and government responsibility for the welfare of the nation's poor and neglected people.

Now their views were brought directly into the
40 White House. ER lobbied for them personally with her new administrative allies, in countless auditoriums, as a radio broadcaster, and in monthly, weekly, and, by 1936, daily columns. Called "Eleanor Everywhere," she was interested in everyone.

Every life was sacred and worthy, to be improved by education, employment, health care, and affordable housing. Her goal was simple, a life of dignity and decency for all. She was uninterested in complex theories, and demanded action for betterment. She feared
50 violent revolution, but was not afraid of socialism—and she courted radicals.

As fascism and communism triumphed in Europe and Asia, ER and FDR were certain that there was a middle way, what ER called an American "revolution without bloodshed." Her abiding conviction, however,
55 was that nothing good would happen to promote the people's interest unless the people themselves organized to demand government responses. A people's movement required active citizen participation, and
60 ER's self-appointed task was to agitate and inspire community action, encourage united democratic movements for change.

Between 1933 and 1938, while the Depression raged and the New Deal unfolded, ER worked with the
65 popular front. She called for alliances of activists to fight poverty and racism at home, and to oppose isolationism internationally.

Active with the women's peace movement, ER spoke regularly at meetings of the Women's International League for Peace and Freedom, and the Conference on the Cause and Cure of War. She departed, however, from pacifist and isolationist positions and encouraged military preparedness, collective security, and ever-widening alliances.

Between 1933 and 1938 ER published countless articles and six books. She wrote in part for herself, to clear her mind and focus her thoughts. But she also wrote to disagree with her husband. From that time to this, no other First Lady has actually rushed for her pen to jab her husband's public decisions. But ER did so routinely, including in her 1938 essay *This Troubled World*, which was a point-by-point rejection of FDR's major international decisions.

To contemplate ER's life of example and responsibility is to forestall gloom. She understood, above all, that politics is not an isolated individualist adventure. She sought alliances, created community, worked with movements for justice and peace. Against great odds, and under terrific pressure, she refused to withdraw
90 from controversy. She brought her network of agitators and activists into the White House, and never considered a political setback a permanent defeat. She enjoyed the game, and weathered the abuse.

11. As she is revealed in the passage, ER is best described as:
- A. socially controversial but quietly cooperative.
 - B. politically courageous and socially concerned.
 - C. morally strong and deeply traditional.
 - D. personally driven but calmly moderate.

12. The author presents ER's accomplishments as exceptional because ER:
- F. brought politically unpopular views to the forefront of the nation's politics.
 - G. was the first public figure to introduce political roles for women.
 - H. was a political pioneer struggling alone for social reform.
 - J. replaced community action with more powerful White House networks.
13. According to the passage, ER believed that social reform should include all of the following EXCEPT:
- A. promoting community action.
 - B. developing universal education.
 - C. supporting affordable housing.
 - D. establishing involved theories.
14. Based on the passage, ER's approach to social reform can best be characterized as:
- F. passionate and theoretical.
 - G. patient and flexible.
 - H. simplistic and isolationist.
 - J. progressive and determined.
15. It can reasonably be inferred from the passage that at the time ER began working for social reform, the United States was:
- A. deeply committed to reforms in education and health care.
 - B. experiencing a time of national prosperity that contributed to ER's ideals concerning the public welfare.
 - C. concentrating on affairs at home due to isolationist policies and the spread of democracy overseas.
 - D. unsupportive of the idea that the government was responsible for the welfare of its poor and neglected.
16. According to the last paragraph, which of the following statements would the author most likely make with regard to ER's vision and ideals?
- F. ER considered politics a game and played only when she knew she could win.
 - G. ER worked with agitators and remained dedicated to the pursuit of justice and peace in victory and defeat.
 - H. ER placed herself in the position of president, making decisions that determined White House policy.
 - J. ER saw herself as the country's role model and personally responsible for bringing about change.
17. In terms of the passage as a whole, one of the main functions of the third paragraph (lines 13–19) is to suggest that:
- A. ER's successes in various professional pursuits helped prepare her to take action in the political world.
 - B. ER had avoided the political spotlight in her personal pursuits.
 - C. ER had competing and conflicting interests during her first year as first lady.
 - D. while ER had many personal accomplishments, little could have prepared her for life as the first lady.
18. According to the passage, the primary principle underlying ER's goals was that:
- F. every person deserved a dignified and decent life.
 - G. as first lady, she could talk about things that had never been discussed before.
 - H. through radio and columns, she could show she was interested in every person.
 - J. she must lead a bloodless American revolution.
19. The passage states that ER believed the relationship between a people and their government should be:
- A. begun and carried out as if it were an isolated, individualist adventure.
 - B. formed and modeled by the White House.
 - C. based on organized, widespread citizen participation.
 - D. controlled through radio broadcasts and formal channels.
20. In the context of the passage, the author's statement that ER "enjoyed the game, and weathered the abuse" (line 93) most nearly means that ER:
- F. enjoyed her individualist adventure in politics even if criticized.
 - G. preferred to be a team player rather than take the lead.
 - H. embraced the political life and accepted criticism as part of her work.
 - J. understood political games and so did not take politics or criticism very seriously.

Passage III

HUMANITIES: This passage is adapted from the essay “The Interior Life” by Annie Dillard, which appeared in her book *An American Childhood* (©1987 by Annie Dillard).

The interior life is often stupid. Its egoism blinds it and deafens it; its imagination spins out ignorant tales, fascinated. It fancies that the western wind blows on the Self, and leaves fall at the feet of the Self for a reason, and people are watching. A mind risks real ignorance for the sometimes paltry prize of an imagination enriched. The trick of reason is to get the imagination to seize the actual world—if only from time to time.

When I was five, I would not go to bed willingly because something came into my room. My sister Amy, two years old, was asleep in the other bed. What did she know? She was innocent of evil. There was no messiness in her, no roughness for things to cling to, only a charming and charmed innocence that seemed then to protect her, an innocence I needed but couldn't muster. Since Amy was asleep, furthermore, and since when I needed someone most I was afraid to stir enough to wake her, she was useless.

I lay alone and was almost asleep when the thing entered the room by flattening itself against the open door and sliding in. It was a transparent, luminous oblong. I could see the door whiten at its touch; I could see the blue wall turn pale where it raced over it, and see the maple headboard of Amy's bed glow. It was a swift spirit; it was an awareness. It made noise. It had two joined parts, a head and a tail. It found the door, wall, and headboard; and it swiped them, charging them with its luminous glance. After its fleet, searching passage, things looked the same, but weren't.

I dared not blink or breathe. If it found another awareness, it would destroy it.

Every night before it got to me it gave up. It hit my wall's corner and couldn't get past. It shrank completely into itself and vanished. I heard the rising roar it made when it died or left. I still couldn't breathe. I knew that it could return again alive that same night.

Sometimes it came back, sometimes it didn't. Most often, restless, it came back. The light stripe slipped in the door, ran searching over Amy's wall, stopped, stretched lunatic at the first corner, raced wailing toward my wall, and vanished into the second corner with a cry. So I wouldn't go to bed.

It was a passing car whose windshield reflected the corner streetlight outside. I figured it out one night.

Figuring it out was as memorable as the oblong itself. Figuring it out was a long and forced ascent to the very rim of being, to the membrane of skin that both separates and connects the inner life and the outer world. I climbed deliberately from the depths like a diver who releases the monster in his arms and hauls

himself hand over hand up an anchor chain till he meets the ocean's sparkling membrane and bursts through it; he sights the sunlit, becalmed hull of his boat, which had bulked so ominously from below.

I recognized the noise it made when it left. That is, the noise it made called to mind, at last, my daytime sensations when a car passed—the sight and noise together. A car came roaring down hushed Edgerton Avenue in front of our house, stopped, and passed on shrieking as its engine shifted up the gears. What, precisely, came into the bedroom? A reflection from the car's oblong windshield. Why did it travel in two parts? The window sash split the light and cast a shadow.

Night after night I labored up the same long chain of reasoning, as night after night the thing burst into the room where I lay awake.

There was a world outside my window and contiguous to it. Why did I have to keep learning this same thing over and over? For I had learned it a summer ago, when men with jackhammers broke up Edgerton Avenue. I had watched them from the yard. When I lay to nap, I listened. One restless afternoon I connected the new noise in my bedroom with the jackhammer men I had been seeing outside. I understood abruptly that these worlds met, the outside and the inside. “Outside,” then, was conceivably just beyond my windows.

The world did not have me in mind. It was a coincidental collection of things and people, of items, and I myself was one such item—a child walking up the sidewalk, whom anyone could see or ignore. The things in the world did not necessarily cause my overwhelming feelings; the feelings were inside me, beneath my skin, behind my ribs, within my skull. They were even, to some extent, under my control.

I could be connected to the outer world by reason, if I chose, or I could yield to what amounted to a narrative fiction, to a show in light projected on the room's blue walls.

21. Which of the following statements best describes the structure of this passage?

- A. It begins and ends with a series of assertions that surround a story used by the narrator to support and elaborate on those assertions.
- B. It contains a highly detailed anecdote that the narrator uses to show how the claims she makes in the first paragraph are wrong.
- C. It compares and contrasts the narrator's perspective on an incident in her life with the perspectives of several other people, such as her parents.
- D. It consists mainly of a story about a recent event in the narrator's life that she feels taught her an interesting but ultimately insignificant lesson.

22. In terms of mood, which of the following best describes lines 9–44?
- F. A steadily increasing feeling of tension
 - G. A consistently high level of tension
 - H. A growing feeling of tension that is finally broken
 - J. A feeling of tension frequently undermined by the narrator’s use of irony and humor
23. The narrator develops the third paragraph (lines 19–29) mainly through:
- A. detached philosophical musings on the nature of the object she sees.
 - B. a detailed description of what she did to try to keep the object out of her room.
 - C. sensory details vividly depicting the object and its movements.
 - D. imaginative speculation on what might be causing the object to appear.
24. The narrator indicates that one reason she did not wake her sister Amy when “something” came into their room was because:
- F. Amy had previously asked the narrator to stop waking her up during the night.
 - G. the narrator knew she could muster her own charmed innocence.
 - H. Amy had already figured out what the thing was before going to sleep.
 - J. the narrator was afraid of alerting the thing to her own presence.
25. It can reasonably be inferred from the passage that the narrator regards her initial discovery of the truth about the object entering her bedroom as:
- A. deflating, because the object turned out to be so ordinary.
 - B. disappointing, because she felt she should have solved the mystery many years ago.
 - C. satisfying, because she could at last ignore the object and go to sleep.
 - D. significant, because solving the mystery led to important insights.
26. It can most reasonably be inferred that for the narrator, the image of the diver bursting through “the ocean’s sparkling membrane” (line 52) symbolizes her:
- F. fear of monsters and of the object in her bedroom.
 - G. crossing of the boundary separating her inner and outer lives.
 - H. struggle to maintain the separation between her inner and outer worlds.
 - J. bitterness at entering reality and leaving behind her comforting memories.
27. As it is used in line 87, the phrase “a show in light” most nearly refers to:
- A. a fictional story the narrator has read.
 - B. a movie the narrator saw at a theater.
 - C. the work of reason in linking a person to the outer world.
 - D. a fantasy created by the mind.
28. The narrator uses the images in lines 3–5 primarily to depict the interior life’s tendency to engage in:
- F. deceptive self-absorption.
 - G. vital self-examination.
 - H. useful analysis of nature.
 - J. fierce debates with itself.
29. Which of the following statements best paraphrases lines 5–8?
- A. The imagination lacks value and should be ignored in favor of paying attention to the actual world.
 - B. Reason can enhance the imagination but at the expense of experience in the actual world.
 - C. Rather than become isolated, the imagination should connect to the actual world at least occasionally.
 - D. Reason, not the imagination, is the best way to appreciate and enrich the actual world.
30. By her statements in lines 77–80, the narrator is most nearly asserting that:
- F. in her world, adults are generally considered more important than children.
 - G. she, like everyone and everything else, was a small part of a larger world.
 - H. it still mattered greatly whether people saw or ignored her.
 - J. she was less valuable than other people in her world.

Passage IV

NATURAL SCIENCE: This passage is adapted from “Publish and Punish: Science’s Snowball Effect” by Jon Van (©1997 by The Chicago Tribune Company).

It’s a scientific finding so fundamental that it certainly will make the history books and maybe snag a Nobel Prize if it pans out, but the notion that cosmic snowballs are constantly pelting Earth is something
5 Louis Frank just as soon would have ducked.

Frank is the University of Iowa physicist whose research led him to declare more than a decade ago that Earth is being bombarded by hundreds of house-sized comets day after day that rain water on our planet and
10 are the reason we have oceans. That weather report caused the widely respected scientist to acquire a certain reputation among his colleagues as a bit unstable, an otherwise estimable fellow whose hard work may have pushed him over the edge.

Frank and his associate, John Sigwarth, probably went a way toward salvaging their reputations when they presented new evidence that leaves little doubt Earth is indeed being bombarded by *something* in a manner consistent with Frank’s small-comet theory.
20 Rather than gloating or anticipating glory, Frank seemed relieved that part of a long ordeal was ending. “I knew we’d be in for it when we first put forth the small-comet theory,” Frank conceded, “but I was naive about just how bad it would be. We were outvoted by
25 about 10,000 to 1 by our colleagues. I thought it would have been more like 1,000 to 1.”

To the non-scientist this may seem a bit strange. After all, the point of science is to discover information and insights about how nature works. Shouldn’t every
30 scientist be eager to overturn existing ideas and replace them with his or her own? In theory, that is the case, but in practice, scientists are almost as loath to embrace radically new ideas as the rest of us.

“Being a scientist puts you into a constant schizophrenic existence,” contends Richard Zare, chairman of the National Science Board. “You have to believe and yet question beliefs at the same time. If you are a complete cynic and believe nothing, you do nothing and get
40 nowhere, but if you believe too much, you fool yourself.”

It was in the early 1980s when the small-comet theory started to haunt Frank and Sigwarth, who was Frank’s graduate student studying charged particles called plasmas, which erupt from the sun and cause the
45 aurora borealis (northern lights). As they analyzed photos of the electrical phenomena that accompany sunspots, they noted dark specks appearing in several images from NASA’s Dynamics Explorer 1 satellite. They assumed these were caused by static in the transmission.
50

After a while their curiosity about the dark spots grew into a preoccupation, then bordered on obsession.

Try as they did, the scientists couldn’t find any plausible explanation of the pattern of dark spots that
55 appeared on their images. The notion that the equipment was picking up small amounts of water entering Earth’s upper atmosphere kept presenting itself as the most likely answer.

Based on their images, the Iowa scientists estimated 20 comets an hour—each about 30 feet or so
60 across and carrying 100 tons of water—were bombarding the Earth. At that rate, they would produce water vapor that would add about an inch of water to the planet every 10,000 years, Frank concluded. That may
65 not seem like much, but when talking about a planet billions of years old, it adds up.

Such intimate interaction between Earth and space suggests a fundamentally different picture of human evolution—which depends on water—than is commonly presented by scientists. Frank had great difficulty getting his ideas into a physics journal 11 years ago and was almost hooted from the room when he presented his theory at scientific meetings. Despite the derision, colleagues continued to respect Frank’s main-
70 stream work on electrically charged particles in space and the imaging cameras he designed that were taken aboard recent NASA spacecraft to explore Earth’s polar regions.

Unbeknown to most, in addition to gathering information on the northern lights, Frank and Sigwarth designed the equipment to be able to snatch better views of any small comets the spacecraft might happen upon. It was those images from the latest flights that caused even harsh critics of the small-comet theory to
85 concede that some water-bearing objects appear to be entering Earth’s atmosphere with regularity.

To be sure, it has not been proved that they are comets, let alone that they have anything to do with the oceans. But Frank’s evidence opens the matter up to
90 study. Had he been a researcher of lesser standing, his theory probably would have died long ago.

31. Which of the following conclusions about new theories in science can reasonably be drawn from the passage?
- A. Important new theories will eventually be accepted, no matter how controversial they are or who proposes them.
 - B. Important but unusual new theories have a better chance at acceptance when they are proposed by well-respected scientists.
 - C. Research on new, nontraditional theories is widely respected within the scientific community.
 - D. Scientists welcome the opportunity to overturn existing ideas in favor of useful new theories.

32. Which of the following best describes how Frank's colleagues perceived him after he first presented the small-comet theory?
- F. Their doubts about the theory led them to also question his work on particles in space.
 - G. They felt his theory had ruined his reputation as a widely respected scientist.
 - H. He acquired a reputation among them as someone who had worked hard to develop his theory.
 - J. They still respected his traditional research but felt he was overly committed to an improbable theory.
33. The passage indicates that at the time Frank and Sigwarth presented new evidence supporting the small-comet theory, Frank most nearly felt:
- A. relieved but bitter about how he had been treated.
 - B. grateful that ridicule of his work would end.
 - C. proud that he had been proved right.
 - D. satisfied and filled with anticipation of glory.
34. The author uses the fourth paragraph (lines 27–33) primarily to:
- F. continue his earlier criticisms of scientists.
 - G. reveal the role science serves in society.
 - H. present then undermine common perceptions of scientists.
 - J. explain the difference between theoretical and practical scientific research.
35. According to the passage, the research that led to the development of the small-comet theory began with a project originally intended to study:
- A. the electrical activity accompanying sunspots.
 - B. water entering Earth's upper atmosphere.
 - C. static in satellite transmissions.
 - D. specks in satellite images.
36. The main function of lines 64–66 in terms of the eighth paragraph (lines 59–66) as a whole is to:
- F. give a sense of proportion to the numbers provided earlier in the paragraph.
 - G. point out the limitations of the evidence provided by the Iowa scientists.
 - H. supplement the paragraph's description of the comets with additional details about their size and capacity.
 - J. provide readers with a sense of how old the planet really is.
37. It can reasonably be inferred from the passage that within the scientific community the year the passage was published, the small-comet theory was:
- A. tremendously unpopular and condemned for its incompleteness.
 - B. widely accepted and seen as conclusive.
 - C. regarded as tentative but deemed worthy of consideration.
 - D. seen as correct by most scientists but was highly criticized by some.
38. The author italicizes the word *something* in line 18 most likely to emphasize the:
- F. great skepticism with which critics regard Frank and Sigwarth's new evidence.
 - G. remaining uncertainty about what exactly is bombarding Earth.
 - H. lack of doubt among scientists about the small-comet theory's practical value.
 - J. concern among scientists about the usefulness of Frank and Sigwarth's methods of collecting evidence.
39. When Richard Zare says that scientists lead a "constant schizophrenic existence" (lines 34–35), he most nearly means that they:
- A. often suffer psychologically from the demands of their work.
 - B. tend to be either complete cynics or people who believe too much.
 - C. are often guilty of either doing nothing or of fooling themselves.
 - D. have to maintain a balance between accepting and challenging ideas.
40. It can reasonably be inferred that Frank and Sigwarth conducted the study of the dark specks they found with a:
- F. detached, scientific mindset.
 - G. casual interest that developed into a mild curiosity.
 - H. steadily increasing level of involvement.
 - J. great intensity that began when they discovered the specks.

END OF TEST 3

STOP! DO NOT TURN THE PAGE UNTIL TOLD TO DO SO.

DO NOT RETURN TO A PREVIOUS TEST.



SCIENCE TEST

35 Minutes—40 Questions

DIRECTIONS: There are seven passages in this test. Each passage is followed by several questions. After reading a passage, choose the best answer to each question and fill in the corresponding oval on your answer document. You may refer to the passages as often as necessary.

You are NOT permitted to use a calculator on this test.

Passage 1

Many bacteria contain *plasmids* (small, circular DNA molecules). Plasmids can be transferred from 1 bacterium to another. For this to occur, the plasmid *replicates* (produces a linear copy of itself). The relative position of the genes is the same on the original plasmid and on the linear copy, except that the 2 ends of the linear copy do not immediately connect.

While replication is occurring, 1 end of the linear copy leaves the donor bacterium and enters the recipient bacterium. Thus, the order in which the genes are replicated is the same as the order in which they are transferred. Unless this process is interrupted, the entire plasmid is transferred, and its 2 ends connect in the recipient bacterium.

Four students studied the way in which 6 genes (F, X, R, S, A, and G) on a specific plasmid were donated by a type of bacterium (see the figure). The students determined that the entire plasmid is transferred in 90 min and that the rate of transfer is constant. They also determined that the genes are evenly spaced around the plasmid, so 1 gene is transferred every 15 min. They disagreed, however, about the order in which the genes are replicated and thus transferred. Four models are presented.

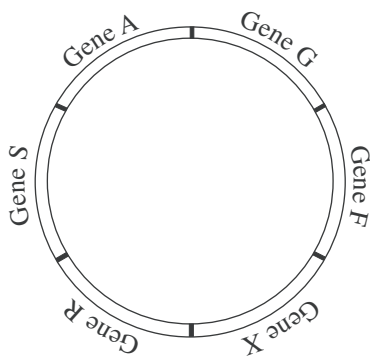

Student 1

Replication always begins between Gene F and Gene X. Gene X is replicated first and Gene F is replicated last.

Student 2

Replication always begins between Gene F and Gene X. However, the direction of replication varies. If Gene F is replicated first, Gene X is replicated last. Conversely, if Gene X is replicated first, Gene F is replicated last.

Student 3

Replication can begin between any 2 genes. Replication then proceeds around the plasmid in a clockwise direction (with respect to the figure). Thus, if Gene S is replicated first, Gene A is replicated second, and Gene R is replicated last.

Student 4

Replication can begin between any 2 genes. Likewise, replication can proceed in either direction. So the order of replication varies.

- Based on the information presented, if the transfer of the linear copy was interrupted 50 min after transfer began, how many complete genes would have been transferred to the recipient bacterium?

A. 2
B. 3
C. 4
D. 5

- Based on the model presented by Student 3, if all 6 genes are replicated and the first gene replicated is Gene G, the third gene replicated would be:

F. Gene F.
G. Gene A.
H. Gene S.
J. Gene X.



3. Which students believe that any of the 6 genes on the plasmid can be the first gene transferred to a recipient bacterium?
- A. Students 2 and 3
 - B. Students 2 and 4
 - C. Students 3 and 4
 - D. Students 2, 3, and 4
4. Suppose that the model presented by Student 1 is correct and that the transfer of genes between 2 bacteria was interrupted after 45 min. Based on the information provided, which of the following genes would NOT have been transferred from the donor bacterium to the recipient bacterium?
- F. Gene G
 - G. Gene X
 - H. Gene R
 - J. Gene S
5. Suppose that Student 2's model is correct and that the transfer of genes between 2 bacteria was interrupted after 30 min. Under these conditions, which of the following genes would definitely NOT be transferred from the donor bacterium to the recipient bacterium?
- A. Gene A
 - B. Gene R
 - C. Gene G
 - D. Gene X
6. Suppose that all 6 genes are transferred from a donor bacterium to a recipient bacterium. Under this condition, which student(s) would argue that Gene A could be the last gene transferred?
- F. Student 2 only
 - G. Student 4 only
 - H. Students 2 and 4 only
 - J. Students 3 and 4 only
7. Suppose that the transfer of genes between 2 bacteria was interrupted, that the last gene transferred was Gene A, and that no incomplete copies of a gene were transferred. Based on this information, Student 1 would say that transfer was most likely interrupted how many minutes after the transfer began?
- A. 15
 - B. 30
 - C. 45
 - D. 60

**Passage II**

Color images of the surface of Io, one of Jupiter's moons, show plumes of gas that resemble Earth's geysers and active volcanoes that emit flows of molten material. The materials ejected from Io's volcanoes and plumes rapidly solidify at Io's cold surface temperatures. Scientists believe that these materials may be one of several *allotropes* (forms) of sulfur (S), or a sulfur compound. The following studies were performed to determine the composition of these materials.

Study 1

In a laboratory, scientists measured the *reflectances* (the fraction of light striking a surface that is reflected by that surface) of 4 allotropes of S (red, white, orange, and brown) and of a sulfur compound (sulfur dioxide [SO_2]). Reflectances were measured at visible-light wavelengths between $0.35 \mu\text{m}$ (micrometers) and $0.60 \mu\text{m}$. Figure 1 shows the data for the various S allotropes and for SO_2 .

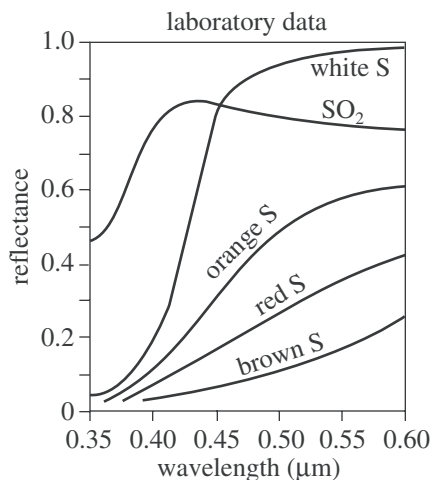

Figure 1

Io's *whole-disk reflectance* (the reflectance of Io's entire visible surface measured all at once) was measured at 2 different times. Figure 2 shows these data along with reflectance data calculated using a computer model. This model shows what combination of materials from Figure 1 would produce the closest match to the measured reflectance data. According to the model, the overall composition of Io's surface is 15% SO_2 , 50% orange S, 20% red S, and 15% white S.

whole-disk data and
computer model

Figure 2

Study 2

At 2 different times, reflectances were measured of the crater floors of 2 volcanoes on Io: Pele and Surt. Figure 3 shows the reflectance data.

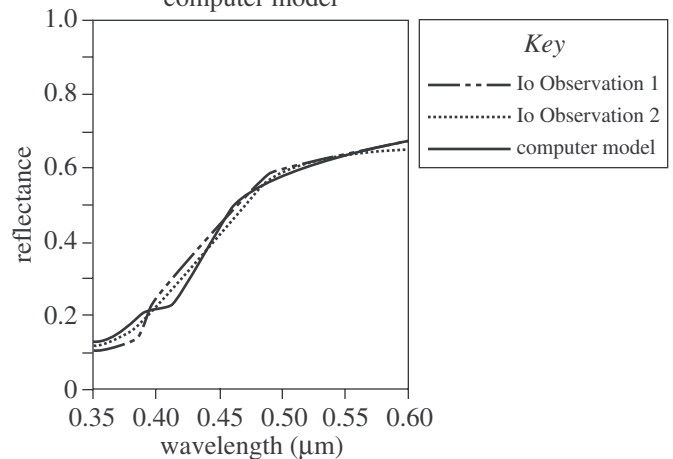
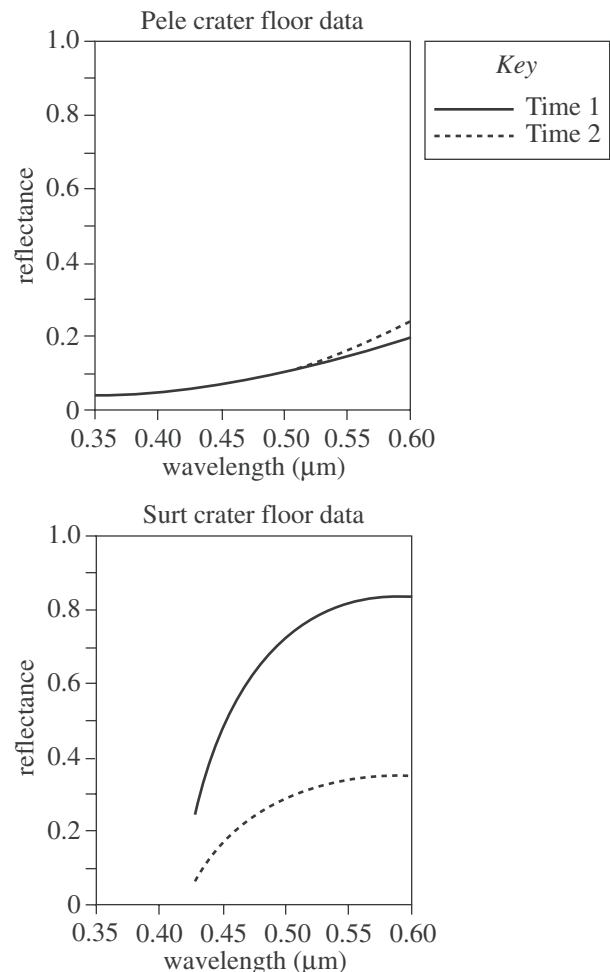

Figure 3



Study 3

Reflectance data were taken from several large plumes and several small plumes on Io. The averaged data are in Figure 4.

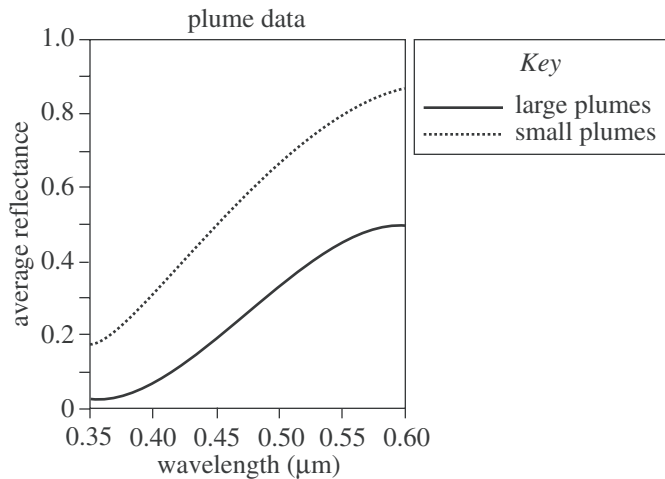

Figure 4

Figures 1, 3, and 4 adapted from Alfred McEwen and Laurence Soderblom, "Two Classes of Volcanic Plumes on Io." ©1983 by Academic Press, Inc.

Figure 2 adapted from Julianne Moses and Douglas Nash, "Phase Transformations and the Spectral Reflectance of Solid Sulfur: Can Metastable Sulfur Allotropes Exist on Io?" ©1991 by Academic Press, Inc.

8. At the wavelengths used in Study 1, as the wavelength of the light increases, the reflectances of the S allotropes and of SO₂ do which of the following?

	S allotropes	SO ₂
F.	Increase only	Increase only
G.	Increase only	Increase, then decrease
H.	Decrease only	Decrease only
J.	Decrease only	Increase, then decrease

9. According to Study 3, compared with the corresponding average reflectance for small plumes, large plumes on Io have an average reflectance at a given wavelength that is:

- A. always higher.
 B. always the same.
 C. always lower.
 D. sometimes higher and sometimes lower.

10. According to Study 1, the reflectance of white S at a wavelength of 0.40 μm is closest to which of the following?

- F. 0.0
 G. 0.1
 H. 0.2
 J. 0.3

11. According to Study 1 and Study 2, the crater floor of the volcano Pele has reflectances most similar to which of the following S allotropes?

- A. White S
 B. Orange S
 C. Red S
 D. Brown S

12. If the averaged reflectances for large plumes and for small plumes had been measured at a wavelength of 0.61 μm in Study 3, those reflectances would have been closest to which of the following?

	Large plumes	Small plumes
F.	0.2	0.5
G.	0.5	0.2
H.	0.5	0.9
J.	0.9	0.5

13. According to Study 1, white S has a reflectance of 0.98 at a wavelength of 0.60 μm. This means that white S reflects:

- A. 2% of the 0.60 μm wavelength light that strikes its surface.
 B. 98% of the 0.60 μm wavelength light that strikes its surface.
 C. 2% of all the visible light that strikes its surface.
 D. 98% of all the visible light that strikes its surface.

**Passage III**

An electrical circuit contained a 12-volt (V) battery, a *resistor* (a device that resists the flow of electricity), a *capacitor* (a device that stores electrical charge and electrical energy), a *voltmeter* (an instrument for measuring voltage), and a switch, as shown in Figure 1.

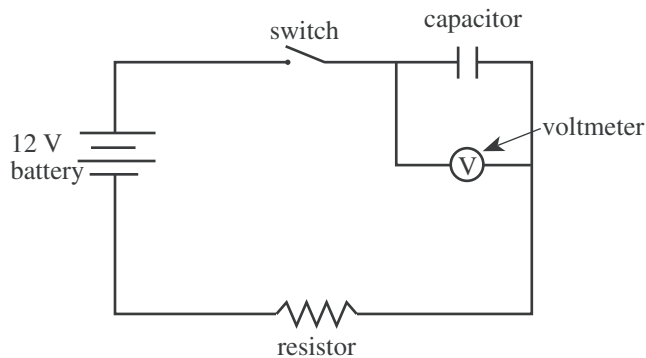

Figure 1

Some students studied the behavior of the circuit.

Experiment 1

The students used a 1×10^7 ohm (Ω) resistor and a capacitor with a *capacitance* of 1×10^{-6} farad (F). (Capacitance is a measure of the maximum amount of electrical charge and electrical energy a capacitor can store.) The capacitor was initially uncharged. At time zero, the students simultaneously closed the switch and started a stopwatch. At time zero and at 12 sec intervals thereafter, they recorded the voltage across the capacitor. Their results are shown in Table 1.

Time (sec)	Voltage across capacitor (V)
0	0.0
12	8.4
24	10.9
36	11.7
48	11.9
60	12.0

Experiment 2

Using the $1 \times 10^7 \Omega$ resistor and several different capacitors, the students determined the length of time from when the switch was closed until the voltage across the capacitor reached 6 V. Their results are shown in Table 2.

Capacitance ($\times 10^{-6}$ F)	Time to reach 6 V across capacitor (sec)
1.2	8.3
0.6	4.2
0.3	2.1
0.1	0.7

Experiment 3

The students conducted the same procedure described in Experiment 2, except that they used a constant capacitance of 1×10^{-6} F and several different resistors. Their results are shown in Table 3.

Resistance ($\times 10^7 \Omega$)	Time to reach 6 V across capacitor (sec)
0.75	5.2
0.50	3.5
0.25	1.7

14. In Experiment 1, the *time constant* of the circuit was the time required for the voltage across the capacitor to reach approximately 7.6 V. The time constant of the circuit used in Experiment 1 was:

- F. less than 12 sec.
- G. between 12 sec and 24 sec.
- H. between 24 sec and 36 sec.
- J. greater than 36 sec.

15. If, in Experiment 2, a 1.5×10^{-6} F capacitor had been used, the time required for the voltage across the capacitor to reach 6 V would have been closest to:

- A. 4.2 sec.
- B. 7.0 sec.
- C. 10.5 sec.
- D. 15.0 sec.



16. The main purpose of Experiment 3 was to determine how varying the:

- F. battery's voltage affected the resistor's resistance at a given time.
- G. capacitor's capacitance affected the time required for the voltage across the capacitor to reach a set value.
- H. capacitor's capacitance affected the voltage across the battery at a given time.
- J. resistor's resistance affected the time required for the voltage across the capacitor to reach a set value.

17. Based on Figure 1, to measure the voltage across the resistor only, which of the following circuits should one use?

A.

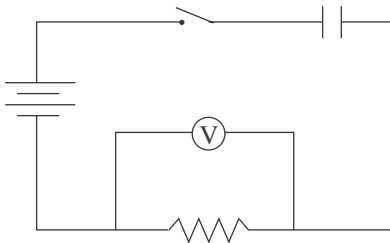

B.

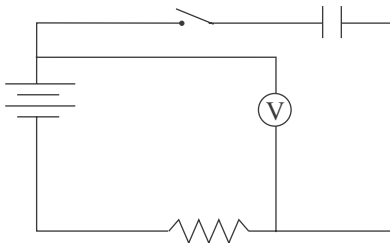

C.

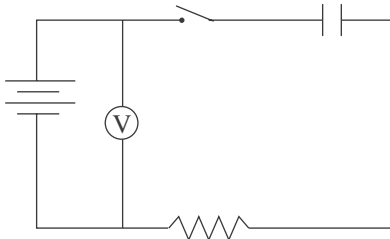

D.

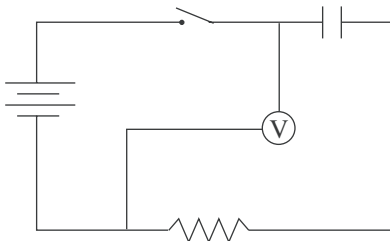

18. Consider a circuit like that shown in Figure 1. Based on Experiments 2 and 3, the voltage across the capacitor will reach a given value in the shortest amount of time if the circuit contains which of the following capacitances and resistances, respectively?

- F. 0.1×10^{-6} F, $0.3 \times 10^7 \Omega$
- G. 0.1×10^{-6} F, $1.0 \times 10^7 \Omega$
- H. 1.2×10^{-6} F, $0.3 \times 10^7 \Omega$
- J. 1.2×10^{-6} F, $1.0 \times 10^7 \Omega$

19. Consider the following hypothesis: In a circuit arranged as in Figure 1 containing a battery, a capacitor, and a constant resistance, as capacitance increases, the time required to reach a given voltage across the capacitor increases. Do the experiments support this hypothesis?

- A. Yes; in Experiment 1, as capacitance increased, the time required to reach a given voltage increased.
- B. Yes; in Experiment 2, as capacitance increased, the time required to reach a given voltage increased.
- C. No; in Experiment 1, as capacitance increased, the time required to reach a given voltage decreased.
- D. No; in Experiment 2, as capacitance increased, the time required to reach a given voltage decreased.



Passage IV

A *bomb calorimeter* is used to determine the amount of heat released when a substance is burned in oxygen (Figure 1). The heat, measured in kilojoules (kJ), is calculated from the change in temperature of the water in the bomb calorimeter. Table 1 shows the amounts of heat released when different foods were burned in a bomb calorimeter. Table 2 shows the amounts of heat released when different amounts of sucrose (table sugar) were burned. Table 3 shows the amounts of heat released when various chemical compounds were burned.

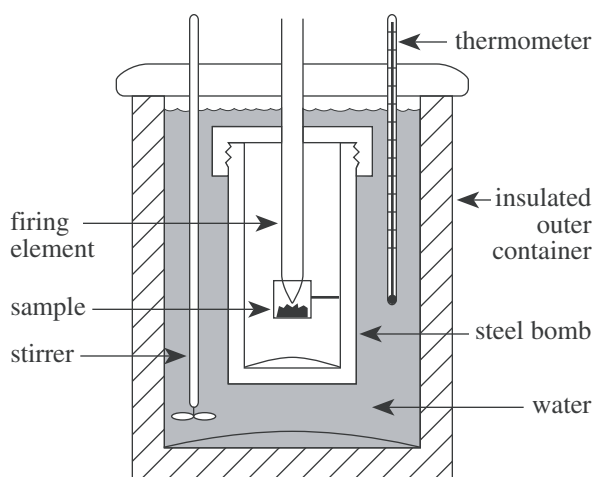

Figure 1

Figure 1 adapted from Antony C. Wilbraham, Dennis D. Staley, and Michael S. Matta, *Chemistry*. ©1995 by Addison-Wesley Publishing Company, Inc.

Food	Mass (g)	Change in water temperature (°C)	Heat released (kJ)
Bread	1.0	8.3	10.0
Cheese	1.0	14.1	17.0
Egg	1.0	5.6	6.7
Potato	1.0	2.7	3.2

Table 1 adapted from American Chemical Society, *ChemCom: Chemistry in the Community*. ©1993 by American Chemical Society.

Amount of sucrose (g)	Heat released (kJ)
0.1	1.6
0.5	8.0
1.0	16.0
2.0	32.1
4.0	64.0

Chemical compound	Molecular formula	Mass (g)	Heat released (kJ)
Methanol	CH ₃ OH	0.5	11.4
Ethanol	C ₂ H ₅ OH	0.5	14.9
Benzene	C ₆ H ₆	0.5	21.0
Octane	C ₈ H ₁₈	0.5	23.9

20. According to Tables 1 and 2, as the mass of successive sucrose samples increased, the change in the water temperature produced when the sample was burned most likely:

F. increased only.
 G. decreased only.
 H. increased, then decreased.
 J. remained the same.



21. Which of the following graphs best illustrates the relationship between the heat released by the foods listed in Table 1 and the change in water temperature?

A.

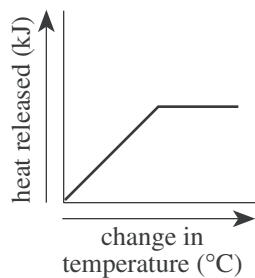

C.

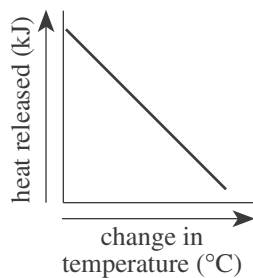

B.

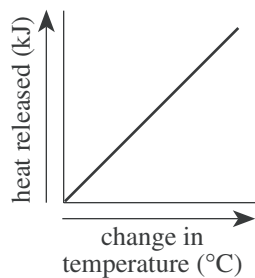

D.

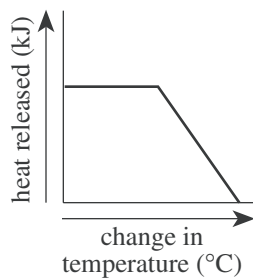

22. Based on the data in Table 2, one can conclude that when the mass of sucrose is decreased by one-half, the amount of heat released when it is burned in a bomb calorimeter will:

- F. increase by one-half.
- G. decrease by one-half.
- H. increase by one-fourth.
- J. decrease by one-fourth.

23. Which of the following lists the foods from Tables 1 and 2 in increasing order of the amount of heat released per gram of food?

- A. Potato, egg, bread, sucrose, cheese
- B. Sucrose, cheese, bread, egg, potato
- C. Bread, cheese, egg, potato, sucrose
- D. Sucrose, potato, egg, bread, cheese

24. Based on the information in Tables 1 and 2, the heat released from the burning of 5.0 g of potato in a bomb calorimeter would be closest to which of the following?

- F. 5 kJ
- G. 10 kJ
- H. 15 kJ
- J. 20 kJ

**Passage V**

Density is defined as the mass of a substance divided by its volume:

$$\text{density} = \frac{\text{mass}}{\text{volume}}$$

Table 1 lists the phases and the densities, in grams per cubic centimeter (g/cm^3), of various pure substances at 25°C and 1 atmosphere (atm) of pressure.

Table 1		
Substance	Phase	Density (g/cm^3)
Arsenic	solid	5.73
Glucose	solid	1.56
Iron	solid	7.86
Lead	solid	11.34
Zinc	solid	7.14
Ethanol	liquid	0.79
Ethyl ether	liquid	0.71
Glycerol	liquid	1.26
Mercury	liquid	13.59
Freon-12	gas	0.00495
Krypton	gas	0.00343
Methane	gas	0.00065

Figure 1 shows how the density of liquid water changes with temperature.

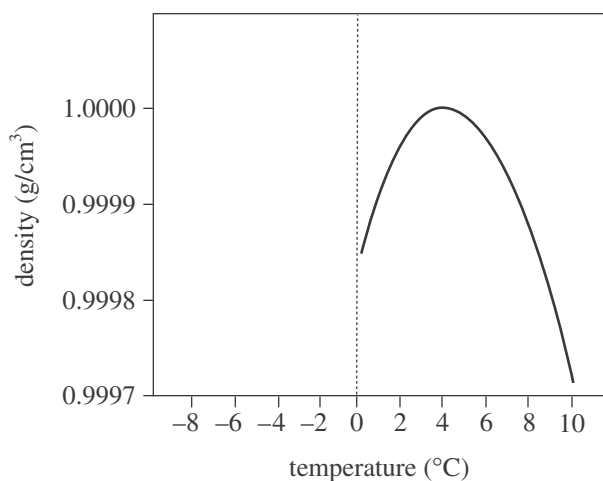

Figure 1

Figure 2 shows how the density of solid water changes with temperature.

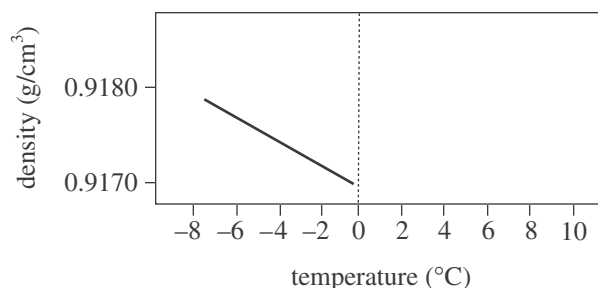

Figure 2

Figures adapted from John C. Kotz and Keith F. Purcell, *Chemistry & Chemical Reactivity*. ©1987 by CBS College Publishing.

25. According to Figure 1, as the temperature of liquid water decreases from 10°C to 0°C , the density:
- increases only.
 - decreases only.
 - decreases, then increases.
 - increases, then decreases.
26. A student claimed that "If the masses of 1 cm^3 of any solid and 1 cm^3 of any liquid are compared, the mass of the solid will be greater." Do the data in Table 1 support his claim?
- No; lead has a higher density than any of the liquids listed.
 - No; mercury has a higher density than any of the solids listed.
 - Yes; lead has a higher density than any of the liquids listed.
 - Yes; mercury has a higher density than any of the solids listed.
27. Which of the following hypotheses about the relationship between the temperature and the density of a solid is best supported by the data in Figure 2? As the temperature of a solid increases, the density of the solid:
- increases only.
 - decreases only.
 - increases, then decreases.
 - decreases, then increases.



28. Equal amounts of ethyl ether, mercury, and water (density = 0.9971 g/cm^3) at 25°C are poured into a single beaker. Three distinct layers of liquid form in the beaker. Based on the data in Table 1, which of the following diagrams represents the order, from top to bottom, of the liquids in the beaker?

F.

Ethyl ether
Water
Mercury

G.

Ethyl ether
Mercury
Water

H.

Mercury
Water
Ethyl ether

J.

Water
Ethyl ether
Mercury

29. According to Figure 1, 100 g of water at 4°C would exactly fill a container having which of the following volumes?

- A. 1 cm^3
 B. 10 cm^3
 C. 100 cm^3
 D. $1,000 \text{ cm}^3$

**Passage VI**

The clearing of rain forests results in *forest fragmentation* (the breakup of large forest tracts into small patches). Researchers predicted that fragmentation would result in a decrease in animal populations and *aboveground tree biomass* (AGTB) in the resulting fragments. They did 4 studies to test this prediction.

Study 1

The researchers monitored the AGTB of twenty-five 100 m \times 100 m forest plots near areas that had recently been cleared of vegetation. The distance from the center of each plot to the nearest clearing was measured. Figure 1 shows the average change per plot in AGTB in metric tons per year (t/yr) over 17 yr.

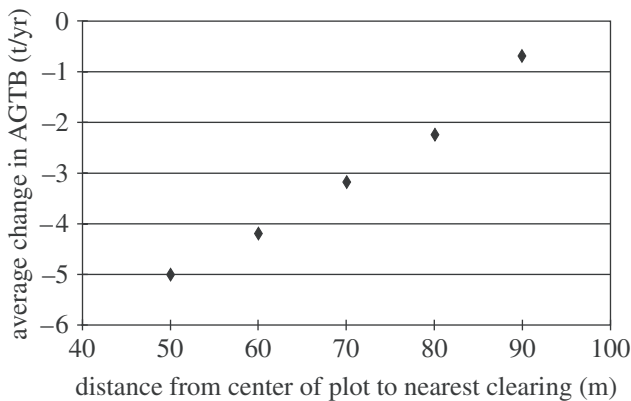

Figure 1

Study 2

Twenty-five 100 m \times 100 m forest plots were monitored as in Study 1. The center of each of these plots was at least 500 m from the nearest clearing. The average change in AGTB over 17 yr for these 25 plots was 0 t/yr.

Study 3

Researchers monitored sixteen 100 m \times 100 m forest plots near areas that had recently been cleared of vegetation. Each plot was bordered on 1 side by a clearing. Figure 2 shows the average cumulative percent change in AGTB at these plots following fragmentation. (Note: Year 0 represents results prior to fragmentation.)

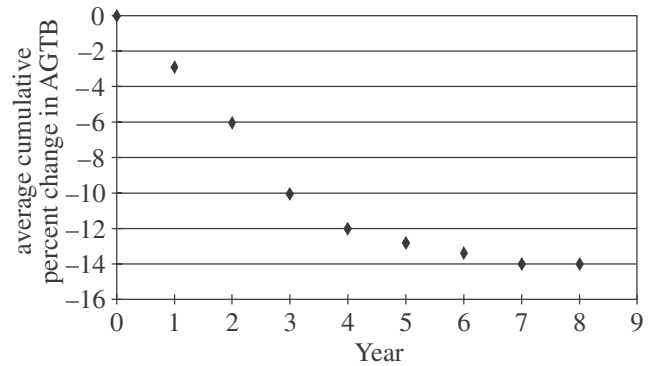

Figure 2

Study 4

Researchers trapped and released birds in 10 forest fragments adjacent to areas that had recently been cleared of vegetation. Three types of birds were monitored: insectivores, frugivores (fruit eaters), and hummingbirds. Figure 3 shows the number of captures per 1,000 hours (hr) of trapping. (Note: Year 0 represents results prior to fragmentation.)

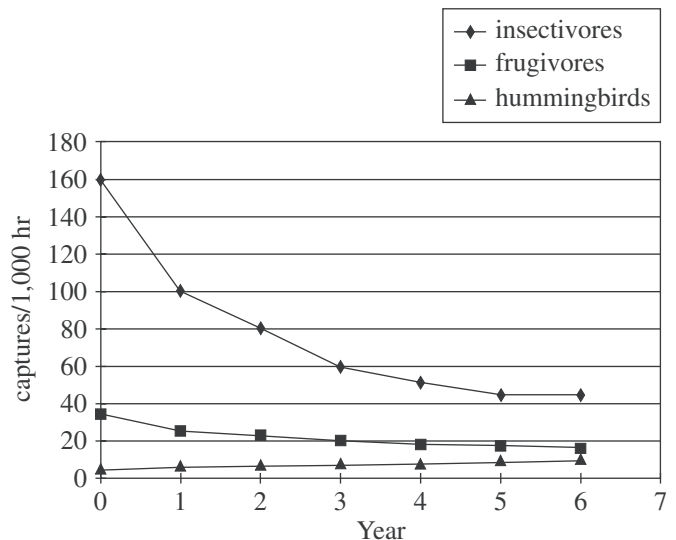

Figure 3

Figures adapted from William F. Laurance et al., "Biomass Collapse in Amazonian Forest Fragments." ©1998 by the American Association for the Advancement of Science.



30. In Study 4, as time increased from Year 0 to Year 6, the captures/1,000 hr of frugivores:
- F. decreased only.
 - G. increased only.
 - H. decreased, then increased.
 - J. increased, then decreased.
31. Based on the results of Study 4, how did fragmentation most likely affect the population sizes of insectivores and hummingbirds in the fragments studied?
- A. Fragmentation increased the population sizes of both insectivores and hummingbirds.
 - B. Fragmentation decreased the population sizes of both insectivores and hummingbirds.
 - C. Fragmentation increased the population size of insectivores and decreased the population size of hummingbirds.
 - D. Fragmentation decreased the population size of insectivores and increased the population size of hummingbirds.
32. Based on the results of Study 1, if the distance from the center of a $100\text{ m} \times 100\text{ m}$ plot were 75 m from the nearest clearing, the expected average change in AGTB at the plot over 17 yr would be closest to which of the following values?
- F. -1.1 t/yr
 - G. -2.6 t/yr
 - H. $+1.1\text{ t/yr}$
 - J. $+2.6\text{ t/yr}$
33. After examining the results of Study 2, a student concluded that the AGTB at each of the 25 plots remained constant. Which of the following alternative explanations is also consistent with the results?
- A. The AGTB at all 25 plots increased.
 - B. The AGTB at all 25 plots decreased.
 - C. The AGTB at some of the plots increased and the AGTB at some of the plots decreased.
 - D. The AGTB at plots bounded by forest increased and the AGTB at plots bounded by clearings remained constant.
34. Which of the following sets of results from the studies is *least* consistent with the prediction proposed by the researchers?
- F. The results of Study 1 for AGTB
 - G. The results of Study 3 for AGTB
 - H. The results of Study 4 for frugivores
 - J. The results of Study 4 for hummingbirds
35. In Study 4, the researchers trapped birds for 10,000 hr per year. Thus, how many insectivores were trapped in Year 2 ?
- A. 80
 - B. 100
 - C. 800
 - D. 1,000



Passage VII

Glaciers deposit *till* (a poorly sorted sediment). If glaciers repeatedly advance over an area and then melt back, thick till deposits may form. Figure 1 shows a vertical core taken through layers of till, non-glacial sediments, and bedrock at a site in Canada. The *resistivity* (an electrical property of a material) and CO₂ measurements taken along the core are also shown. Resistivity is related to a sediment's particle sizes, compaction, and mineral composition. Table 1 shows the average percent sand, silt, and clay contents and descriptions of the various till layers.

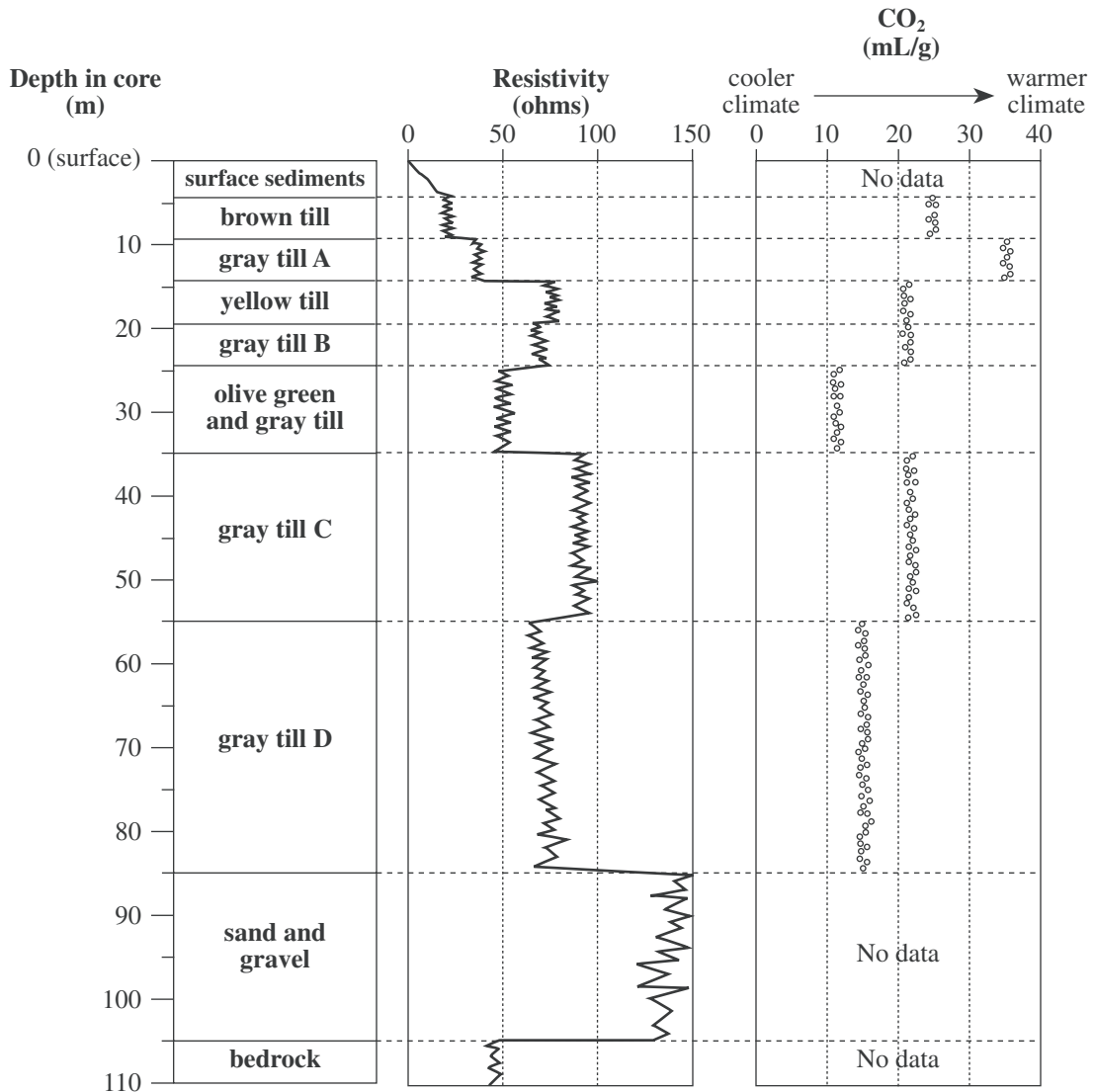

Figure 1



Depth of till layer (m)	Description of till	Average percent by volume of:		
		larger particle → smaller particle		
		sand	silt	clay
4–9	brown (oxidized*)	54.1	31.7	14.2
9–14	gray A	44.8	36.6	18.6
14–19	yellow (oxidized)	43.5	31.7	24.8
19–24	gray B	37.4	34.3	28.3
24–35	olive green and gray	25.5	34.3	40.2
35–55	gray C	31.7	33.6	34.7
55–85	gray D	37.5	31.7	30.8

*Oxidized sediments have at some time been exposed to the air. Sediments that have been *deprived* of oxygen will be gray or green.

Figure 1 and Table 1 adapted from E. A. Christiansen, "Pleistocene Stratigraphy of the Saskatoon Area, Saskatchewan, Canada: An Update." ©1992 by the Geological Association of Canada.

36. A sample of gray till was recovered from another core taken from a nearby area. The table below shows the results of an analysis of the sample.

Percent by volume of:			Resistivity (ohms)	CO ₂ content (mL/g)
sand	silt	clay		
31.5	33.7	34.8	85	22

Based on these data and the data provided in Figure 1 and Table 1, the sample of gray till corresponds most closely with which till from Figure 1 ?

- F. Gray till A
 G. Gray till B
 H. Gray till C
 J. Gray till D
37. According to Figure 1, the *oldest* glacial advance in this area deposited which of the following till layers?
 A. Gray till A
 B. Yellow till
 C. Olive green and gray till
 D. Gray till D
38. According to Figure 1, which of the following statements best describes how the resistivity of the sand and gravel layer compares to the resistivity of the till layers? The resistivity measured in the sand and gravel layer is:
 F. lower than the resistivities measured in any of the till layers.
 G. higher than the resistivities measured in any of the till layers.
 H. the same as the resistivities measured in the surface sediments.
 J. lower than the resistivities measured in the bedrock.
39. The average resistivity of the bedrock in the core is most similar to the average resistivity of which of the following till layers?
 A. Yellow till
 B. Gray till B
 C. Olive green and gray till
 D. Gray till C
40. The sediments being deposited at the present time at the site where the core was taken have a much higher CO₂ content than any of the tills. Given this information and the information in Figure 1, the CO₂ content of sediments recently deposited at the site would most likely be in which of the following ranges?
 F. Less than 10 mL/g
 G. Between 10 mL/g and 25 mL/g
 H. Between 25 mL/g and 35 mL/g
 J. Greater than 35 mL/g

END OF TEST 4

STOP! DO NOT RETURN TO ANY OTHER TEST.

[See Note on page 56.]

Note: If you plan to take the ACT Writing Test, take a short break and then continue testing on page 57.

If you do not plan to take the ACT Writing Test, turn to page 59 for instructions on scoring your multiple-choice tests.

Practice Writing Test

Your Signature (do not print): _____

Print Your Name Here: _____

Your Date of Birth:									
<input type="text"/>	<input type="text"/>	-	<input type="text"/>	<input type="text"/>	-	<input type="text"/>	<input type="text"/>	<input type="text"/>	<input type="text"/>
Month		Day		Year					

Form 06A

The ACT[®] | ACT ASSESSMENT[®] WRITING TEST BOOKLET

Directions

This is a test of your writing skills. You will have thirty (30) minutes to write an essay in English. Before you begin planning and writing your essay, read the writing prompt carefully to understand exactly what you are being asked to do. Your essay will be evaluated on the evidence it provides of your ability to express judgments by taking a position on the issue in the writing prompt; to maintain a focus on the topic throughout the essay; to develop a position by using logical reasoning and by supporting your ideas; to organize ideas in a logical way; and to use language clearly and effectively according to the conventions of standard written English.

You may use the unlined pages in this test booklet to plan your essay. These pages will not be scored. ***You must write your essay in pencil on the lined pages in the answer folder.*** Your writing on those lined pages will be scored. You may not need all the lined pages, but to ensure you have enough room to finish, do NOT skip lines. You may write corrections or additions neatly between the lines of your essay, but do NOT write in the margins of the lined pages. ***Illegible essays cannot be scored, so you must write (or print) clearly.***

If you finish before time is called, you may review your work. Lay your pencil down immediately when time is called.

DO NOT OPEN THIS BOOKLET UNTIL TOLD TO DO SO.

ACT Assessment Writing Test Prompt

Many high school libraries use some of their limited funding to subscribe to popular magazines with articles that are interesting to students. Despite limited funding, some educators support this practice because they think having these magazines available encourages students to read. Other educators think school libraries should not use limited funds to subscribe to these magazines because they may not be related to academic subjects. In your opinion, should high school libraries subscribe to popular magazines?

In your essay, take a position on this question. You may write about either one of the two points of view given, or you may present a different point of view on this question. Use specific reasons and examples to support your position.

Note

- Your actual test booklet will have blank space for you to plan your essay. For this practice test, you can use scratch paper.
- You may wish to remove pages 75–78 to respond to this Writing Test prompt.
- When you have finished, read pages 66–72 for information and instructions on scoring your practice essay.

5

Scoring Your Tests

How to Score the Multiple-Choice Tests

Follow the instructions below and on the following pages to score the multiple-choice portions of the practice test and to review your performance.

Raw Scores

The number of questions you answered correctly on each test and in each subscore area is your raw score. Because there are many forms of the ACT, each containing different questions, some forms will be slightly easier (and some slightly harder) than others. A raw score of 67 on one form of the English Test, for example, may be about as difficult to earn as a raw score of 70 on another form of that test.

To compute your raw scores, check your answers with the scoring keys on pages 60–62. Count the number of correct answers for each of the four tests and seven subscore areas, and enter the number in the blanks provided on those pages. These numbers are your raw scores on the tests and subscore areas.

Scale Scores

To adjust for the small differences that occur among different forms of the ACT, the raw scores for tests and subscore areas are converted into *scale scores*. Scale scores are printed on the reports sent to you and your college and scholarship choices.

When your raw scores are converted into scale scores, it becomes possible to compare your scores with those of examinees who completed different test forms. For example, a scale score of 26 on the English Test has the same meaning regardless of the form of the ACT on which it is based.

To determine the scale scores corresponding to your raw scores on the practice test, use the score conversion tables on pages 63–64. Table 1 on page 63 shows the raw-to-scale score conversions for the total tests, and Table 2 on page 64 shows the raw-to-scale score conversions for the subscore areas. Because each form of the ACT is unique, each form has somewhat different conversion tables. Consequently, these tables provide only approximations of the raw-to-scale score conversions that would apply if a different form of the ACT were taken. Therefore, the scale scores obtained from the practice test would not be expected to match precisely the scale scores received from a national administration of the ACT.

Computing the Composite Score

The Composite score is the average of the four scale scores in English, Mathematics, Reading, and Science. If you left any of these tests blank, a Composite score cannot be calculated. If you take the ACT Plus Writing, your Writing Test results do **not** affect your Composite score.

Percent At or Below

Even scale scores don't tell the whole story of your test performance. You may want to know how your scores compare to the scores of other students who take the ACT.

The norms table (Table 3 on page 65) enables you to compare your scores on the sample test with the scores of recent high school graduates who tested as sophomores, juniors, or seniors. The numbers reported in Table 3 are cumulative percents. A cumulative percent is the percent of students who scored *at or below* a given score. For example, a Composite score of 20 has a cumulative percent of 50. This means that 50% of the ACT-tested high school students had a Composite score of 20 or lower.

Remember that your scores and percent at or below on the practice test are only *estimates* of the scores that you will obtain on an actual form of the ACT. Test scores are only one indicator of your level of academic knowledge and skills. Consider your scores in connection with your grades, your performance in outside activities, and your career interests.

College Readiness Standards™

To add to the information you receive about your performance on the ACT, we have developed College Readiness Standards. These Standards help you to more fully understand what your total test score means for each academic area assessed: English, Mathematics, Reading, Science, and Writing. The College Readiness Standards describe the types of skills, strategies, and understandings you will need to make a successful transition from high school to college. For English, Mathematics, Reading, and Science, standards are provided for six score ranges that reflect the progression and complexity of the skills measured by the ACT tests. For Writing, standards are provided for five score ranges. The College Readiness Standards can be found at www.act.org/standards.

Reviewing Your Performance on the Practice Multiple-Choice Tests

After you have determined your scale scores, consider the following as you evaluate how you did on the multiple-choice portions of the practice test.

- Did you run out of time before you completed a test? If so, reread the information in this booklet on pacing yourself. Perhaps you need to adjust the way you used your time in responding to the questions. It is to your advantage to answer every question and pace yourself so that you can do so. Remember there is no penalty for guessing.
- Did you spend too much time trying to understand the directions to the tests? If so, read the directions for each test again thoroughly. The directions in the practice test are exactly like the directions that will appear in your test booklet on test day. Make sure you understand them now, so you won't have to spend too much time studying them when you take the actual test.
- Review the questions that you missed. Did you select a response that was an incomplete answer or that did not directly respond to the question being asked? Try to figure out what you overlooked in answering the questions.
- Did a particular type of question confuse you? Did the questions you missed come from a particular subscore area? In reviewing your responses to the practice test, check to see whether a particular type of question or a particular subscore area was more difficult for you or took more of your time.

Scoring Keys for the ACT Practice Test

Use the scoring key for each test to score your answer document for the multiple-choice tests. Mark a “1” in the blank for each question you answered correctly. Add up the numbers in each subscore area and enter the total number correct for each subscore area in the blanks provided. Also enter the total number correct for each test in the blanks provided. The total number correct for each test is the sum of the number correct in each subscore area.

Test 1: English—Scoring Key

Subscore Area*			Subscore Area*			Subscore Area*		
Key	UM	RH	Key	UM	RH	Key	UM	RH
1.	D	_____	26.	F	_____	51.	C	_____
2.	F	_____	27.	A	_____	52.	H	_____
3.	B	_____	28.	H	_____	53.	B	_____
4.	J	_____	29.	D	_____	54.	J	_____
5.	A	_____	30.	G	_____	55.	D	_____
6.	G	_____	31.	C	_____	56.	J	_____
7.	A	_____	32.	J	_____	57.	C	_____
8.	G	_____	33.	A	_____	58.	H	_____
9.	A	_____	34.	H	_____	59.	B	_____
10.	J	_____	35.	C	_____	60.	J	_____
11.	C	_____	36.	G	_____	61.	C	_____
12.	J	_____	37.	D	_____	62.	F	_____
13.	A	_____	38.	H	_____	63.	B	_____
14.	G	_____	39.	A	_____	64.	F	_____
15.	C	_____	40.	J	_____	65.	D	_____
16.	J	_____	41.	C	_____	66.	H	_____
17.	B	_____	42.	F	_____	67.	B	_____
18.	J	_____	43.	C	_____	68.	G	_____
19.	A	_____	44.	F	_____	69.	C	_____
20.	F	_____	45.	D	_____	70.	J	_____
21.	C	_____	46.	G	_____	71.	D	_____
22.	F	_____	47.	A	_____	72.	F	_____
23.	A	_____	48.	G	_____	73.	B	_____
24.	J	_____	49.	D	_____	74.	H	_____
25.	B	_____	50.	G	_____	75.	D	_____

Number Correct (Raw Score) for:	
Usage/Mechanics (UM) Subscore Area	_____ (40)
Rhetorical Skills (RH) Subscore Area	_____ (35)
Total Number Correct for English Test (UM + RH)	_____ (75)

* UM = Usage/Mechanics
RH = Rhetorical Skills

0661C

Test 2: Mathematics—Scoring Key

Subscore Area*				Subscore Area*			
Key	EA	AG	GT	Key	EA	AG	GT
1.	A	_____		31.	E	_____	
2.	K	_____		32.	F		_____
3.	B	_____		33.	C	_____	
4.	G		_____	34.	J	_____	
5.	E	_____		35.	B		_____
6.	H	_____		36.	K	_____	
7.	E	_____		37.	C	_____	
8.	G	_____		38.	J	_____	
9.	B		_____	39.	C		_____
10.	J		_____	40.	H	_____	
11.	E	_____		41.	A	_____	
12.	J		_____	42.	F	_____	
13.	B	_____		43.	D	_____	
14.	G		_____	44.	F		_____
15.	C		_____	45.	C		_____
16.	G		_____	46.	K		_____
17.	A	_____		47.	C	_____	
18.	H		_____	48.	J	_____	
19.	C	_____		49.	D	_____	
20.	K	_____		50.	J	_____	
21.	B	_____		51.	E	_____	
22.	K		_____	52.	J	_____	
23.	A	_____		53.	A	_____	
24.	F	_____		54.	K		_____
25.	D		_____	55.	B		_____
26.	J		_____	56.	H		_____
27.	A	_____		57.	A	_____	
28.	H	_____		58.	K		_____
29.	C		_____	59.	E	_____	
30.	G		_____	60.	J	_____	

Number Correct (Raw Score) for:	
Pre-Alg./Elem. Alg. (EA) Subscore Area	_____ (24)
Inter. Alg./Coord. Geo. (AG) Subscore Area	_____ (18)
Plane Geo./Trig. (GT) Subscore Area	_____ (18)
Total Number Correct for Math Test (EA + AG + GT)	_____ (60)

* EA = Pre-Algebra/Elementary Algebra
 AG = Intermediate Algebra/Coordinate Geometry
 GT = Plane Geometry/Trigonometry

0661C

Test 3: Reading—Scoring Key

	<u>Key</u>	<u>Subscore Area*</u>		<u>Key</u>	<u>Subscore Area*</u>		<u>Key</u>	<u>Subscore Area*</u>	
		<u>SS</u>	<u>AL</u>		<u>SS</u>	<u>AL</u>		<u>SS</u>	<u>AL</u>
1.	B		_____	15.	D	_____	29.	C	_____
2.	J		_____	16.	G	_____	30.	G	_____
3.	C		_____	17.	A	_____	31.	B	_____
4.	F		_____	18.	F	_____	32.	J	_____
5.	C		_____	19.	C	_____	33.	B	_____
6.	J		_____	20.	H	_____	34.	H	_____
7.	A		_____	21.	A	_____	35.	A	_____
8.	H		_____	22.	H	_____	36.	F	_____
9.	D		_____	23.	C	_____	37.	C	_____
10.	G		_____	24.	J	_____	38.	G	_____
11.	B	_____		25.	D	_____	39.	D	_____
12.	F	_____		26.	G	_____	40.	H	_____
13.	D	_____		27.	D	_____			
14.	J	_____		28.	F	_____			

Number Correct (Raw Score) for:	
Social Studies/Sciences (SS) Subscore Area	_____ (20)
Arts/Literature (AL) Subscore Area	_____ (20)
Total Number Correct for Reading Test (SS + AL)	_____ (40)

* SS = Social Studies/Sciences
AL = Arts/Literature

Test 4: Science—Scoring Key

<u>Key</u>	<u>Key</u>	<u>Key</u>	
1. B	_____	29. C	_____
2. J	_____	30. F	_____
3. C	_____	31. D	_____
4. F	_____	32. G	_____
5. A	_____	33. C	_____
6. J	_____	34. J	_____
7. D	_____	35. C	_____
8. G	_____	36. H	_____
9. C	_____	37. D	_____
10. H	_____	38. G	_____
11. D	_____	39. C	_____
12. H	_____	40. J	_____
13. B	_____		
14. F	_____		

Number Correct (Raw Score) for:	
Total Number Correct for Science Test	_____ (40)

0661C

TABLE 1
Procedures Used to Obtain Scale Scores
From Raw Scores for the ACT Practice Test

On each of the four multiple-choice tests on which you marked any responses, the total number of correct responses yields a raw score. Use the table below to convert your raw scores to scale scores. For each test, locate and circle your raw score or the range of raw scores that includes it in the table below. Then, read across to either outside column of the table and circle the scale score that corresponds to that raw score. As you determine your scale scores, enter them in the blanks provided on the right. The highest possible scale score for each test is 36. The lowest possible scale score for any test on which you marked any response is 1.

Next, compute the Composite score by averaging the four scale scores. To do this, add your four scale scores and divide the sum by 4. If the resulting number ends in a fraction, round it off to the nearest whole number. (Round down any fraction less than one-half; round up any fraction that is one-half or more.) Enter this number in the blank. This is your Composite score. The highest possible Composite score is 36. The lowest possible Composite score is 1.

	<u>Your Scale Score</u>
English	_____
Mathematics	_____
Reading	_____
Science	_____
<hr/>	
Sum of scores	_____
Composite score (sum ÷ 4)	_____

NOTE: If you left a test completely blank and marked no items, do not list a scale score for that test. If any test was completely blank, do not calculate a Composite score.

Scale Score	Raw Scores				Scale Score
	Test 1 English	Test 2 Mathematics	Test 3 Reading	Test 4 Science	
36	75	60	38-40	40	36
35	73-74	58-59	37	—	35
34	71-72	56-57	36	39	34
33	70	55	35	—	33
32	69	54	34	38	32
31	68	52-53	—	—	31
30	67	50-51	33	37	30
29	65-66	48-49	32	36	29
28	64	46-47	30-31	35	28
27	62-63	43-45	29	34	27
26	60-61	41-42	28	32-33	26
25	57-59	39-40	27	30-31	25
24	55-56	37-38	26	29	24
23	53-54	35-36	25	27-28	23
22	50-52	33-34	24	25-26	22
21	47-49	31-32	23	23-24	21
20	44-46	30	22	21-22	20
19	42-43	27-29	21	18-20	19
18	39-41	25-26	20	16-17	18
17	37-38	22-24	19	14-15	17
16	34-36	18-21	17-18	13	16
15	30-33	15-17	16	12	15
14	28-29	12-14	14-15	10-11	14
13	26-27	09-11	12-13	09	13
12	24-25	08	10-11	08	12
11	22-23	06-07	08-09	07	11
10	20-21	05	07	06	10
9	18-19	04	06	05	9
8	15-17	—	05	04	8
7	13-14	03	—	03	7
6	10-12	02	04	—	6
5	08-09	—	03	02	5
4	06-07	—	02	—	4
3	04-05	01	—	01	3
2	02-03	—	01	—	2
1	00-01	00	00	00	1

TABLE 2

Your Scale Subscore

English

Usage/Mechanics (UM)

Rhetorical Skills (RH)

Mathematics

Pre-Algebra/Elem. Algebra (EA)

Inter. Algebra/Coord. Geometry (AG)

Plane Geometry/Trigonometry (GT)

Reading

Social Studies/Sciences (SS)

Arts/Literature (AL)

Procedures Used to Obtain Scale Subscores From Raw Scores for the ACT Practice Test

For each of the seven subscore areas, the total number of correct responses yields a raw score. Use the table below to convert your raw score to scale subscores. For each of the seven subscore areas, locate and circle either the raw score or the range of raw scores that includes it in the table below. Then, read across to either outside column of the table and circle the scale subscore that corresponds to that raw score. As you determine your scale subscores, enter them in the blanks provided on the right. The highest possible scale subscore is 18. The lowest possible scale subscore is 1.

If you left a test completely blank and marked no items, do not list any scale subscores for that test.

Scale Subscore	Raw Scores										Scale Subscore
	Test 1 English		Test 2 Mathematics				Test 3 Reading				
	Usage/ Mechanics	Rhetorical Skills	Pre-Algebra/ Elem. Algebra	Inter. Algebra/ Coord. Geometry	Plane Geometry/ Trigonometry	Social Studies/ Sciences	Arts/ Literature	Social Studies/ Sciences	Arts/ Literature	Social Studies/ Sciences	
18	39-40	35	23-24	18	18	19-20	20	19-20	20	18	
17	38	33-34	22	17	17	17-18	19	17-18	19	17	
16	36-37	31-32	21	16	16	16	18	16	18	16	
15	35	30	20	14-15	14-15	15	17	15	17	15	
14	33-34	28-29	18-19	13	13	13-14	16	13-14	16	14	
13	31-32	26-27	17	11-12	11-12	12	15	12	15	13	
12	29-30	24-25	16	10	10	—	14	—	14	12	
11	27-28	21-23	14-15	9	9	11	13	11	13	11	
10	25-26	19-20	13	07-08	07-08	10	12	10	12	10	
9	23-24	16-18	12	06	06	09	11	07-08	11	9	
8	20-22	14-15	09-11	05	05	06	10	06	10	8	
7	17-19	12-13	07-08	04	04	06	09	06	09	7	
6	15-16	10-11	05-06	03	03	05	07-08	05	07-08	6	
5	13-14	08-09	03-04	02	02	04	05-06	04	05-06	5	
4	10-12	06-07	02	—	—	03	04	03	04	4	
3	08-09	04-05	—	01	01	—	03	02	03	3	
2	05-07	02-03	01	—	—	01	02	01	02	2	
1	00-04	00-01	00	00	00	00	00	00	00	1	

0661C

TABLE 3
Norms Table

Use the norms table below to determine your estimated percent at or below for each of your multiple-choice scale scores.

In the far left column, circle your scale score for the English Test (from page 63). Then read across to the percent at or below column for that test; circle or put a check mark beside the corresponding percent at or below. Use the same procedure for each test (from page 63) and subscore area (from page 64). You may find it easier to use the right column of scale scores for your Science Test and Composite scores.

As you mark your percents at or below, enter them in the blanks provided at the right.

You may also find it helpful to compare your performance with the national mean (average) score for each of the four tests, subscore areas, and the Composite as shown at the bottom of the norms table.

**Your Estimated
Percent At or Below
on Practice Test**

English

Usage/Mechanics _____
Rhetorical Skills _____

Mathematics

Pre-Algebra/Elem. Alg. _____
Alg./Coord. Geometry _____
Plane Geometry/Trig. _____

Reading

Soc. Studies/Sciences _____
Arts/Literature _____

Science

Composite

National Distributions of Cumulative Percents for ACT Test Scores
ACT-Tested High School Graduates of 2003, 2004, and 2005

Score	ENGLISH		MATHEMATICS		READING			SCIENCE		COMPOSITE		Score
	Usage/Mechanics	Rhetorical Skills	Pre-Algebra/Elem. Alg.	Alg./Coord. Geometry	Plane Geometry/Trig.	Soc. Studies/Sciences	Arts/Literature					
36	99		99			99		99		99	36	
35	99		99			99		99		99	35	
34	99		99			98		99		99	34	
33	98		99			97		99		99	33	
32	98		98			96		99		99	32	
31	96		97			94		98		98	31	
30	95		96			92		97		97	30	
29	93		95			90		96		95	29	
28	90		93			87		95		93	28	
27	87		90			83		93		90	27	
26	84		85			79		90		86	26	
25	80		81			75		85		82	25	
24	75		76			70		80		77	24	
23	70		70			65		74		71	23	
22	65		65			59		66		64	22	
21	59		60			53		58		57	21	
20	52		55			48		49		49	20	
19	45		49			42		39		42	19	
18	38	99	42	99	99	35	99	30	99	34	18	
17	32	98	34	98	99	30	99	22	99	27	17	
16	27	94	25	94	98	25	94	16	91	20	16	
15	22	90	15	89	96	20	89	12	86	14	15	
14	16	85	08	83	93	15	83	08	79	09	14	
13	11	79	03	75	86	10	76	05	74	05	13	
12	09	73	01	67	78	05	68	03	66	02	12	
11	06	65	01	59	67	02	60	02	56	01	11	
10	04	56	01	49	55	01	50	01	47	01	10	
09	03	45	01	40	41	01	38	01	38	01	09	
08	02	36	01	31	26	01	28	01	30	01	08	
07	01	26	01	19	16	01	16	01	22	01	07	
06	01	17	01	08	10	01	10	01	15	01	06	
05	01	10	01	03	05	01	06	01	09	01	05	
04	01	06	01	01	03	01	03	01	03	01	04	
03	01	02	01	01	01	01	01	01	01	01	03	
02	01	01	01	01	01	01	01	01	01	01	02	
01	01	01	01	01	01	01	01	01	01	01	01	
Mean	20.4	10.2	10.5	20.6	10.8	10.3	10.4	21.3	10.8	10.9	20.8	20.9
S.D.	5.9	3.7	3.1	5.1	3.4	2.9	3.0	6.0	3.5	3.8	4.6	4.8

Note: These norms are the source of national and state norms, for multiple-choice tests, printed on ACT score reports during the 2005–2006 testing year. Sample size: 3,510,770.

Six-Point Holistic Scoring Rubric for the ACT Writing Test

Papers at each level exhibit *all* or *most* of the characteristics described at each score point.

Score = 6

Essays within this score range demonstrate effective skill in responding to the task.

The essay shows a clear understanding of the task. The essay takes a position on the issue and may offer a critical context for discussion. The essay addresses complexity by examining different perspectives on the issue, or by evaluating the implications and/or complications of the issue, or by fully responding to counterarguments to the writer's position. Development of ideas is ample, specific, and logical. Most ideas are fully elaborated. A clear focus on the specific issue in the prompt is maintained. The organization of the essay is clear: the organization may be somewhat predictable or it may grow from the writer's purpose. Ideas are logically sequenced. Most transitions reflect the writer's logic and are usually integrated into the essay. The introduction and conclusion are effective, clear, and well developed. The essay shows a good command of language. Sentences are varied and word choice is varied and precise. There are few, if any, errors to distract the reader.

Score = 5

Essays within this score range demonstrate competent skill in responding to the task.

The essay shows a clear understanding of the task. The essay takes a position on the issue and may offer a broad context for discussion. The essay shows recognition of complexity by partially evaluating the implications and/or complications of the issue, or by responding to counterarguments to the writer's position. Development of ideas is specific and logical. Most ideas are elaborated, with clear movement between general statements and specific reasons, examples, and details. Focus on the specific issue in the prompt is maintained. The organization of the essay is clear, although it may be predictable. Ideas are logically sequenced, although simple and obvious transitions may be used. The introduction and conclusion are clear and generally well developed. Language is competent. Sentences are somewhat varied and word choice is sometimes varied and precise. There may be a few errors, but they are rarely distracting.

Score = 4

Essays within this score range demonstrate adequate skill in responding to the task.

The essay shows an understanding of the task. The essay takes a position on the issue and may offer some context for discussion. The essay may show some recognition of complexity by providing some response to counterarguments to the writer's position. Development of ideas is adequate, with some movement between general statements and specific reasons, examples, and details. Focus on the specific issue in the prompt is maintained throughout most of the essay. The organization of the essay is apparent but predictable. Some evidence of logical sequencing of ideas is apparent, although most transitions are simple and obvious. The introduction and conclusion are clear and somewhat developed. Language is adequate, with some sentence variety and appropriate word choice. There may be some distracting errors, but they do not impede understanding.

Score = 3

Essays within this score range demonstrate some developing skill in responding to the task.

The essay shows some understanding of the task. The essay takes a position on the issue but does not offer a context for discussion. The essay may acknowledge a counterargument to the writer's position, but its development is brief or unclear. Development of ideas is limited and may be repetitious, with little, if any, movement between general statements and specific reasons, examples, and details. Focus on the general topic is maintained, but focus on the specific issue in the prompt may not be maintained. The organization of the essay is simple. Ideas are logically grouped within parts of the essay, but there is little or no evidence of logical sequencing of ideas. Transitions, if used, are simple and obvious. An introduction and conclusion are clearly discernible but underdeveloped. Language shows a basic control. Sentences show a little variety and word choice is appropriate. Errors may be distracting and may occasionally impede understanding.

Score = 2

Essays within this score range demonstrate inconsistent or weak skill in responding to the task.

The essay shows a weak understanding of the task. The essay may not take a position on the issue, or the essay may take a position but fail to convey reasons to support that position, or the essay may take a position but fail to maintain a stance. There is little or no recognition of a counterargument to the writer's position. The essay is thinly developed. If examples are given, they are general and may not be clearly relevant. The essay may include extensive repetition of the writer's ideas or of ideas in the prompt. Focus on the general topic is maintained, but focus on the specific issue in the prompt may not be maintained. There is some indication of an organizational structure, and some logical grouping of ideas within parts of the essay is apparent. Transitions, if used, are simple and obvious, and they may be inappropriate or misleading. An introduction and conclusion are discernible but minimal. Sentence structure and word choice are usually simple. Errors may be frequently distracting and may sometimes impede understanding.

Score = 1

Essays within this score range show little or no skill in responding to the task.

The essay shows little or no understanding of the task. If the essay takes a position, it fails to convey reasons to support that position. The essay is minimally developed. The essay may include excessive repetition of the writer's ideas or of ideas in the prompt. Focus on the general topic is usually maintained, but focus on the specific issue in the prompt may not be maintained. There is little or no evidence of an organizational structure or of the logical grouping of ideas. Transitions are rarely used. If present, an introduction and conclusion are minimal. Sentence structure and word choice are simple. Errors may be frequently distracting and may significantly impede understanding.

No Score

Blank, Off-Topic, Illegible, Not in English, or Void

How to Score the Writing Test

Two trained readers will score each essay on the actual Writing Test. These readers are trained by reading examples of papers at each score point and by scoring many practice papers. They are given detailed feedback on the correctness of their scores during practice. During actual scoring, score differences of more than one point will be evaluated by a third trained reader to resolve discrepancies. This method is designed to be as objective and impartial as possible. So—how can you rate your *own* practice Writing Test?

It is difficult to be objective about one's own work, and you have not had the extensive training provided to actual readers of the ACT Writing Test. However, it is to your advantage to read your own writing critically. Becoming your own editor helps you grow as a writer and as a reader. So it makes sense for you to evaluate your own practice essay. That having been said, it may also make sense for you to give your practice essay to another reader to get another perspective: perhaps that of a classmate, a parent, or an English teacher, for example. Thinking and talking with others about writing is good preparation for the Writing Test. To rate your essay, you and your reader(s) should read the scoring guidelines and examples, which begin below and continue through page 71, and then assign your practice essay a score of 1 through 6.

In an actual test, each essay will be scored on a scale from 1 (low) through 6 (high). The score is based on the overall impression that is created by all the elements of the

writing. The scores given by the two readers are added together, yielding the score range 2–12 shown in Table 4 on page 72.

Scoring Guidelines (see page 66)

These are the guidelines that should be used to score your essay. These guidelines are also called a “rubric.” Many papers do not fit the exact description at each score point. You should note that the rubric says: “Papers at each level exhibit *all* or *most* of the characteristics in the descriptors.” To score your paper, you should read it and try to determine which paragraph in the rubric best describes most of the characteristics of your essay.

Then (because your Writing Test subscore is the sum of two readers' ratings of your essay), you should multiply your 1–6 score by 2 when you use Table 4, on page 72, to find your Combined English/Writing score. Or, if both you and someone else read and score your practice essay, you could add those scores together.

Percents At or Below

Norms (cumulative percents) were not yet available for the Practice Writing Test at the time this booklet was printed. However, if you register for and take the ACT Plus Writing, a cumulative percent for your Writing Test scores will be included on your Student Report and will be available on our website at www.actstudent.org.

College Readiness Standards

The College Readiness Standards for Writing (see page 59) can be found at www.act.org/standards.

Example Essays and Scoring Explanations

Readers for the ACT Writing Test practice by scoring many essays before they score “live” essays. Although we cannot provide you with the same extensive training these readers receive, reading the example essays that follow will help you better understand some of the characteristics of essays at each score point. You will also be able to read a brief explanation of how each essay was scored. The example essays are in response to the practice prompt given on page 58.

Score = 1

The funding should be used to buy magazines. Some magazines are only for entertainment but some talk about politics and the world. Even the more popular magazine for kids will be chosen, its still the best thing to do. Students like to read about what tells them what movie stars lives are like.

Score Point 1 Scoring Explanation

This essay shows little engagement with the prompt task. The writer does take a clear position (*The funding should be used to buy magazines*) but little is developed in support of that position. Two ideas are offered (*Some magazines are only for entertainment but some talk about politics and the world* and *Students like to read about what tells them what movie stars lives are like*). Both ideas are left unexplored and unexplained. No organization is evident. Transitions (*even, still*) are used but are unclear. No introduction or conclusion is present, unless the statement of position is considered an introduction. The essay's language is clear at the beginning, but later becomes hard to understand. Errors and a lack of logical sequencing also are problems.

Score = 2

Popular magazines would be a good thing, it would pull students into the library and encourage them to read. Some articles in magazines have nothing to do with school, but it still encourages students to read more. Reading is education, no matter if its talking about academics or not.

Many of the subjects in the magazine are school related. If an article is about a girl from another country talking about how she lives, that's school related because it has to do with geography. If it's an article about some part of the body, then that has to do with science.

**Score Point 2
Scoring Explanation**

Essays that earn a score of 2 demonstrate either weak or inconsistent skill in responding to the issue. In this essay, the writer takes a clear position (*Popular magazines would be a good thing*) and offers specific reasons (*it would pull students into the library and encourage them to read* and *Many of the subjects in the magazine are school related*) but development of these reasons is thin. The writer does attempt to explain the second claim with examples (*If an article is about a girl from another country . . . that's . . . geography. If it's . . . the body, then . . . science*), but much more is needed. The second paragraph might be understood to be responding to a counterargument from the prompt that the magazines aren't related to academic subjects. If so, it is a faint reference that should be clearer. The essay indicates organizational structure by separating the two ideas into two separate paragraphs. However, there is no discernible introduction or conclusion. Language use in the essay contains a variety of errors that distract the reader, including a run-on sentence, disagreements of subject and verb, and several misspellings.

Score = 3

I feel that schools should not subscribe to popular magazines. Sometimes the magazine articles are misleading and don't tell the truth. And some students may not know between right and wrong. I get Seventeen magazine every month. There are some subjects in the articles that I feel should not be allowed, or maybe edited. They put in college searches which are helpful, but other articles have girls talking about things that are not right. Not everybody should be reading them. Why should schools subscribe to magazines that have articles that are not right. These articles could make teenagers spend too much time thinking about things that are misleading or not right or a waist of time. Teenagers are sometimes too young to read some of the articles that the popular magazines have.

Also, popular magazines will not help students to be encouraged to read. Popular magazines have short articles that are based on opinion and gossip and they are filled with quizzes and advertisements and how to loose weight. The advertisements show skinny girls and the articles about loosing weight are not good. They are bad for teenagers to see and to read. And the other articles are a waist of time too because they are full of gossip and mostly pictures. If school libraries really want to help students, they need to subscribe to magazines that are academic, like Time and National Geographic.

There is no reason to subscribe to any other kind of popular magazines. If schools libraries did, they would find that popular magazines give students something to do instead of the research they should use the library for. It would be a perfect excuse for hanging out to just look at magazines with their friends. School libraries should not subscribe to popular magazines, especially when funding is limited.

**Score Point 3
Scoring Explanation**

Essays that earn a score point of 3 show developing skill in responding to the task. This essay takes a clear position but does not provide any context for the discussion. A counterargument taken from the prompt is vaguely referenced and refuted (*popular magazines will not help students to be encouraged to read*), but further clarification is needed to explain why short, gossipy articles are of no use in encouraging students to read. The essay contains limited movement between general statements and specific examples (*They put in college searches which are helpful*). Focus on the specific issue in the prompt wavers because of the somewhat vague discussion the writer gives on the general, negative aspects of popular magazines (*These articles could make teenagers spend too much time thinking about things that are misleading or not right or a waist of time*). All the ideas would benefit from more development. This writer's ideas are grouped logically throughout the essay. There is only a single use of a transition (*Also*). The opening and closing sentences clearly signal an introduction and conclusion, but they lack development. The language usage in this essay demonstrates basic control. Sentences are somewhat varied in length and structure, and words are used correctly. Errors are at times distracting.

Score = 4

High school libraries have only a very limited fund. The big question is how do they spend the fund. Some people think only the magazines that are about academics should be bought, but others point out that if students are interested in what is being read, they will read more, learn more and like school more. This second group is exactly right.

First, anytime someone reads, their learning. Studies show that students who read thirty minutes a day in their free time perform better than those who don't. Students are not going to want to pick up Shakespeare in their study hall, they're going to pick up "Seventeen." If you want them to get in that thirty minutes, you have to give them something they will actually open and look at. Remember its not what we're reading, its just the reading that counts.

Also, popular magazines can help students learn about current events. Its important to keep up with information that hasn't had time to get in the textbooks yet. Many popular magazines contain articles about new health discoveries, wars and events in other countries, and can even provide resources for research papers. This is important for our education.

Most importantly, popular magazines offer a break from the stress of schoolwork. After hours of listening to lectures and taking tests, people need to relax by reading something fun. If their is nothing fun to read, a bad attitude could develop toward libraries and school. This could hurt students much more than it would "hurt" us to read about movie stars and new music during study hall.

In conclusion, for student's mental health, knowledge, and love of reading, popular magazines should stay in our library. While some people may want to debate the issue, the right decision is clear. Interesting magazines are important for students in lots of ways.

**Score Point 4
Scoring Explanation**

Essays that earn a score of 4 demonstrate adequate skill in responding to the task. This essay takes a position on the issue presented in the prompt, but first offers a context for the discussion, and recognizes two different perspectives. The essay offers three ideas to support the writer's position (*anytime someone reads, their learning; popular magazines can help students learn about current events; and popular magazines offer a break*) with adequate development of each. The writer moves ably between general statements and some specific details (*Shakespeare/"Seventeen", health discoveries, wars, hours listening to lectures and taking tests*) and maintains focus throughout the discussion. The essay is clearly organized around a simple 5-paragraph framework. The sequencing of ideas is logical, though predictable, and indicated by transitions (*First, Also, Most importantly, In conclusion*). While the transitions are simple and obvious, they are at least effective in moving the reader through the essay systematically. The introduction and conclusion are clear and somewhat developed, with the introduction offering much necessary information to set up the discussion. The conclusion makes very clear the writer's position and reasoning. Language is adequate, with a variety of sentence constructions and correct word usage. Language errors—mostly spelling—are somewhat distracting.

Score = 5

High school libraries have a dilemma on their hands. Should they buy popular magazines as well as academic books and publications? In a perfect world, our school library would be able to offer everything that's possible and appropriate. But with budget limits throughout the school system, the administration must be sure they're making the best choices of books and magazines, so magazines like "Teen People" and "YM" should not be paid for instead of educational books and publications.

The purpose of school, and school libraries, is learning. Supporters of popular magazines argue that there is something to be learned from any reading material, but I believe some kinds of learning are more important to students futures than other kinds. If the school library has to choose between teaching teenage girls about the achievements of Harriet Tubman and letting them read about their favorite movie star, I know which one I would vote for.

Furthermore, one of the school library's most important functions is offering students the learning resources they might not be able to find or afford on their own. Everybody would agree the school library should have Internet access for the people who don't have a computer at home. Shouldn't the library also offer full sets of encyclopedia, hard cover books and high quality magazines like "National Geographic" to students who can't buy all these materials, especially when they may only need them for one paper all year? On the other hand, anybody can spend \$3.99 at the drugstore to find out about Justin Timberlake's love life if they want to. The school library shouldn't have to finance that. If you're in study hall and you have an urgent celebrity trivia question that just can't wait, you can always use the Internet, at no extra cost to the school.

Reading for pleasure is a great thing, and one of my personal favorite leisure activities, but magazines just for entertainment shouldn't be a priority for school libraries. Learning is the reason for school, and should be first in mind as this decision is made. When funding is so limited, the school library must always put learning materials first.

**Score Point 5
Scoring Explanation**

This essay shows a clear understanding of the task. The writer takes a position ("*Teen People*" and "*YM*" should not be paid for instead of educational books and publications) after establishing a broad context for discussion (*In a perfect world, our school library would be able to offer everything that's possible and appropriate. But with budget limits throughout the school system, the administration must be sure they're making the best choices*). The essay shows recognition of complexity by responding succinctly to counterarguments to the writer's position (*Supporters of popular magazines argue that there is something to be learned from any reading material, but I believe some kinds of learning are more important to students futures than other kinds*). Development of the discussion is specific, with clear movement between claims and the details that explain and support them. Development is also logical, assisted by strong, integrated transitions (*Furthermore, On the other hand*) and carefully sequenced ideas. The introduction and conclusion are both clear and generally well developed, offering necessary context and adding emphasis to clarify the argument. Language is highly competent and engaging, with a lot of sentence variety and some word precision (*urgent celebrity trivia question*). Errors are minimally distracting.

Score = 6

High schools nowadays are struggling to draw the line between what is “educational” and what is not. School programs are cut based on how much educational content they’re perceived to have. Now the administration is trying to purge the libraries of popular magazines because they contain non academic subjects. It’s important that the library buy dictionaries and encyclopedias, but education purists need to be reminded that if you separate “academic” from “non-academic” too strictly, you separate school from the real world it’s supposed to prepare us for.

Educators are the ones who tell us we should spend more time reading. The only way to build the reading comprehension and vocabulary skills so important for getting into and through college is to practice, and that means reading things other than school assignments. No one ever gained reading proficiency from daily struggles through their Chemistry or History textbooks. We read these because we have to, but we would continue reading—even during precious homework free moments—if we had something interesting to turn to. The magazines that teenagers enjoy reading are the ones that cover our interests and address our concerns, like “Seventeen” or “Teen People”. These are the magazines that some would banish from the library.

It’s true that not every page in youth magazines is an intellectual challenge. Many pages show models selling zit cream, or contain “dream date” quizzes. But the critics of popular magazines should take a closer look at them. These same magazines have articles on suicide prevention, the spread of AIDS among teens, and college comparisons—subjects that the adult oriented news media doesn’t cover.

Even the frivolous features have something to teach the reader who wants to learn. All those “Great Looks Cheap” may be a first step toward becoming a smarter consumer. The silly quiz may open up questions about the nature of “scientific proof” or lead to more self-knowledge.

Learning is where you find it, and students may find it in places administrators and librarians might not think to look. Learning can be found in popular magazines as well as approved academic texts. There should be room in the school library for both.

**Score Point 6
Scoring Explanation**

Essays that earn a score point of 6 demonstrate a clear understanding and effective performance of the persuasive task. The writer takes a clear position, develops it throughout the essay, and states it directly in the conclusion (*Learning can be found in popular magazines as well as approved academic texts*). This position is placed in a wider context without disrupting the essay’s focus (*High schools nowadays are struggling to draw the line between what is “educational” and what is not. School programs are cut based on how much educational content they’re perceived to have*).

The essay addresses complexity by anticipating counterarguments to the writer’s position (*It’s true that not every page in youth magazines is an intellectual challenge*) and fully responding to those counterarguments by showing specifically where they are weak (*These same magazines have articles on suicide prevention, the spread of AIDS among teens, and college comparisons—subjects that the adult oriented news media doesn’t cover*).

The writer’s ideas may not be developed evenly over all the paragraphs, but their development is succinct and logical. The essay elaborates general statements (*Even the frivolous features have something to teach the reader who wants to learn*) by moving to more specific details and examples (*All those “Great Looks Cheap” may be a first step toward becoming a smarter consumer*).

The organization of the essay is clear and the logical sequence of ideas grows out of the writer’s intent to persuade. Transitions help the essay flow smoothly from one paragraph to the next (*It’s true that not every page in youth magazines is an intellectual challenge.... Even the frivolous features have something to teach the reader who wants to learn*). The introduction is clear and especially well developed, connecting the writer’s position to a strong critical claim (*if you separate “academic” from “non-academic” too strictly, you separate school from the real world it’s supposed to prepare us for*).

This essay shows a good command of language. Word choice is precise and persuasive (*purge the libraries, frivolous features*). Facility with words and sentence structure enables the writer to maintain a light, amused tone (*The silly quiz may open up questions about the nature of “scientific proof” or lead to more self-knowledge*). There are few errors in this essay, and they scarcely distract the reader.

TABLE 4

Calculating Your ACT Combined English/Writing Score

Complete these steps to calculate your Combined English/Writing Test score for your practice test.

1. Locate your scale score for the English Test on page 63 and enter it here: _____.
2. Enter your Writing Test score (1–6) here _____ and *double it* to get your Writing Test subscore (2–12): _____. (If two people read and scored your Writing Test, you should add those two scores to get your Writing Test subscore.)
3. Use the table below to find your Combined English/Writing score.
 - First, circle your ACT English Test score in the left column.
 - Second, circle your ACT Writing Test subscore at the top of the table.
 - Finally, follow the English Test row across and the Writing Test row down until the two meet. Circle the Combined score where the two columns meet. (For example, if an

English Test score were 19 and a Writing Test subscore were 6, the Combined English/Writing Test score would be 18.)

4. Using the number you circled in the table below, write your Combined English/Writing Test score here: _____. (The highest possible Combined English/Writing score is 36 and the lowest possible score is 1.)

ACT English Test score _____

ACT Writing Test subscore _____

Combined English/Writing Score _____
(from table below)

Combined English/Writing Scale Scores											
English Test Score	Writing Test Subscore										
	2	3	4	5	6	7	8	9	10	11	12
1	1	2	3	4	5	6	7	8	9	10	11
2	2	3	4	5	6	6	7	8	9	10	11
3	2	3	4	5	6	7	8	9	10	11	12
4	3	4	5	6	7	8	9	10	11	12	13
5	4	5	6	7	8	9	10	11	12	12	13
6	5	6	7	7	8	9	10	11	12	13	14
7	5	6	7	8	9	10	11	12	13	14	15
8	6	7	8	9	10	11	12	13	14	15	16
9	7	8	9	10	11	12	13	13	14	15	16
10	8	9	9	10	11	12	13	14	15	16	17
11	8	9	10	11	12	13	14	15	16	17	18
12	9	10	11	12	13	14	15	16	17	18	19
13	10	11	12	13	14	14	15	16	17	18	19
14	10	11	12	13	14	15	16	17	18	19	20
15	11	12	13	14	15	16	17	18	19	20	21
16	12	13	14	15	16	17	18	19	20	20	21
17	13	14	15	16	16	17	18	19	20	21	22
18	13	14	15	16	17	18	19	20	21	22	23
19	14	15	16	17	18	19	20	21	22	23	24
20	15	16	17	18	19	20	21	21	22	23	24
21	16	17	17	18	19	20	21	22	23	24	25
22	16	17	18	19	20	21	22	23	24	25	26
23	17	18	19	20	21	22	23	24	25	26	27
24	18	19	20	21	22	23	23	24	25	26	27
25	18	19	20	21	22	23	24	25	26	27	28
26	19	20	21	22	23	24	25	26	27	28	29
27	20	21	22	23	24	25	26	27	28	28	29
28	21	22	23	24	24	25	26	27	28	29	30
29	21	22	23	24	25	26	27	28	29	30	31
30	22	23	24	25	26	27	28	29	30	31	32
31	23	24	25	26	27	28	29	30	30	31	32
32	24	25	25	26	27	28	29	30	31	32	33
33	24	25	26	27	28	29	30	31	32	33	34
34	25	26	27	28	29	30	31	32	33	34	35
35	26	27	28	29	30	31	31	32	33	34	35
36	26	27	28	29	30	31	32	33	34	35	36

The ACT® PLUS WRITING 2006-2007 National Answer Folder

A NAME, MAILING ADDRESS, AND TELEPHONE
(Please print.)

Last Name _____ First Name _____ MI (Middle Initial) _____

House Number & Street (Apt. No.) or PO Box & No.; or RR & No. _____

City _____ State _____ ZIP Code _____

Area Code _____ Number _____

B MATCH NAME
(First 5 letters of last name)

<input type="radio"/>	<input type="radio"/>	<input type="radio"/>	<input type="radio"/>	<input type="radio"/>
A	A	A	A	A
B	B	B	B	B
C	C	C	C	C
D	D	D	D	D
E	E	E	E	E
F	F	F	F	F
G	G	G	G	G
H	H	H	H	H
I	I	I	I	I
J	J	J	J	J
K	K	K	K	K
L	L	L	L	L
M	M	M	M	M
N	N	N	N	N
O	O	O	O	O
P	P	P	P	P
Q	Q	Q	Q	Q
R	R	R	R	R
S	S	S	S	S
T	T	T	T	T
U	U	U	U	U
V	V	V	V	V
W	W	W	W	W
X	X	X	X	X
Y	Y	Y	Y	Y
Z	Z	Z	Z	Z

C MATCH ID
(Registered examinees only)

<input type="radio"/>	<input type="radio"/>	<input type="radio"/>	<input type="radio"/>	<input type="radio"/>	<input type="radio"/>	<input type="radio"/>	<input type="radio"/>	<input type="radio"/>	<input type="radio"/>
1	1	1	1	1	1	1	1	1	1
2	2	2	2	2	2	2	2	2	2
3	3	3	3	3	3	3	3	3	3
4	4	4	4	4	4	4	4	4	4
5	5	5	5	5	5	5	5	5	5
6	6	6	6	6	6	6	6	6	6
7	7	7	7	7	7	7	7	7	7
8	8	8	8	8	8	8	8	8	8
9	9	9	9	9	9	9	9	9	9
0	0	0	0	0	0	0	0	0	0

D DATE OF BIRTH

Month	Day	Year
<input type="radio"/> Jan.	<input type="radio"/>	<input type="radio"/>
<input type="radio"/> Feb.	<input type="radio"/>	<input type="radio"/>
<input type="radio"/> March	<input type="radio"/> 1	<input type="radio"/> 1
<input type="radio"/> April	<input type="radio"/> 2	<input type="radio"/> 2
<input type="radio"/> May	<input type="radio"/> 3	<input type="radio"/> 3
<input type="radio"/> June	<input type="radio"/> 4	<input type="radio"/> 4
<input type="radio"/> July	<input type="radio"/> 5	<input type="radio"/> 5
<input type="radio"/> Aug.	<input type="radio"/> 6	<input type="radio"/> 6
<input type="radio"/> Sept.	<input type="radio"/> 7	<input type="radio"/> 7
<input type="radio"/> Oct.	<input type="radio"/> 8	<input type="radio"/> 8
<input type="radio"/> Nov.	<input type="radio"/> 9	<input type="radio"/> 9
<input type="radio"/> Dec.	<input type="radio"/> 0	<input type="radio"/> 0

Read the directions below before you begin.

REGISTERED examinees MUST complete blocks A, B, C, and D. Print the requested information in block A. Then, enter the MATCHING INFORMATION in blocks B, C, and D EXACTLY as it appears on your admission ticket, even if any part of the information is missing or incorrect. Fill in the corresponding ovals. If you do not complete these blocks to match your admission ticket EXACTLY, your scores will be delayed. Leave blocks E and F blank.

STANDBY examinees MUST complete blocks A, B, D, E, and F. Print the requested information in block A. Then, enter your identifying information in blocks B and D and fill in the corresponding ovals. Leave block C blank. Enter your Social Security number (SSN) in block E and fill in the corresponding ovals. The SSN will be used to help match your answer document to the registration folder you turned in today. It will be included on reports issued to your college choices. If you do not know your SSN or do not wish to provide it, you may leave it blank. Fill in the Standby Testing oval in block F.



↓ STANDBY TESTING ONLY ↓

E SOCIAL SECURITY NUMBER
(Standby examinees only)

<input type="radio"/>	<input type="radio"/>	<input type="radio"/>	<input type="radio"/>	<input type="radio"/>	<input type="radio"/>	<input type="radio"/>	<input type="radio"/>	<input type="radio"/>	<input type="radio"/>
1	1	1	1	1	1	1	1	1	1
2	2	2	2	2	2	2	2	2	2
3	3	3	3	3	3	3	3	3	3
4	4	4	4	4	4	4	4	4	4
5	5	5	5	5	5	5	5	5	5
6	6	6	6	6	6	6	6	6	6
7	7	7	7	7	7	7	7	7	7
8	8	8	8	8	8	8	8	8	8
9	9	9	9	9	9	9	9	9	9
0	0	0	0	0	0	0	0	0	0

F STANDBY TESTING

Fill in the oval below ONLY if you turned in a standby registration folder at the test center today.

Yes, I am testing as a standby.

USE A SOFT LEAD NO. 2 PENCIL ONLY.
(Do NOT use a mechanical pencil, ink, ballpoint, correction fluid, or felt-tip pens.)

EXAMINEE STATEMENT AND SIGNATURE: After testing, the test supervisor will instruct you to complete this section. Read the statement below.

Statement: I agree to the conditions set forth in the ACT registration booklet or website instructions for this exam, including the arbitration and dispute remedy provisions. I understand that I cannot share any test questions or essay topics with anyone by any form of communication.

Now, copy the certification below on the lines provided (do not print) and sign your name as you would an official document.

Certification: I agree to the statement above and certify that I am the person whose name and address appear on this form.

Your Signature

Today's Date



P.O. BOX 168, IOWA CITY, IOWA 52243-0168

PLEASE DO NOT WRITE IN THIS AREA.



SERIAL #

Cut Here

Marking Directions: Mark only **one** oval for each question. Fill in response completely. Erase errors cleanly without smudging.

Correct mark:

Do NOT use these incorrect or bad marks.

- Incorrect marks:
- Overlapping mark:
- Cross-out mark:
- Smudged erasure:
- Mark is too light:

BOOKLET NUMBER

1	1	1	1	1	1
2	2	2	2	2	2
3	3	3	3	3	3
4	4	4	4	4	4
5	5	5	5	5	5
6	6	6	6	6	6
7	7	7	7	7	7
8	8	8	8	8	8
9	9	9	9	9	9
0	0	0	0	0	0

FORM

--	--	--

Print your 3-character **Test Form** in the boxes above and fill in the corresponding oval at the right.

BE SURE TO FILL IN THE CORRECT FORM OVAL.

0661C

TEST 1

- | | | | | | |
|--------------|--------------|--------------|--------------|--------------|--------------|
| 1 (A B C D) | 14 (F G H J) | 27 (A B C D) | 40 (F G H J) | 53 (A B C D) | 66 (F G H J) |
| 2 (F G H J) | 15 (A B C D) | 28 (F G H J) | 41 (A B C D) | 54 (F G H J) | 67 (A B C D) |
| 3 (A B C D) | 16 (F G H J) | 29 (A B C D) | 42 (F G H J) | 55 (A B C D) | 68 (F G H J) |
| 4 (F G H J) | 17 (A B C D) | 30 (F G H J) | 43 (A B C D) | 56 (F G H J) | 69 (A B C D) |
| 5 (A B C D) | 18 (F G H J) | 31 (A B C D) | 44 (F G H J) | 57 (A B C D) | 70 (F G H J) |
| 6 (F G H J) | 19 (A B C D) | 32 (F G H J) | 45 (A B C D) | 58 (F G H J) | 71 (A B C D) |
| 7 (A B C D) | 20 (F G H J) | 33 (A B C D) | 46 (F G H J) | 59 (A B C D) | 72 (F G H J) |
| 8 (F G H J) | 21 (A B C D) | 34 (F G H J) | 47 (A B C D) | 60 (F G H J) | 73 (A B C D) |
| 9 (A B C D) | 22 (F G H J) | 35 (A B C D) | 48 (F G H J) | 61 (A B C D) | 74 (F G H J) |
| 10 (F G H J) | 23 (A B C D) | 36 (F G H J) | 49 (A B C D) | 62 (F G H J) | 75 (A B C D) |
| 11 (A B C D) | 24 (F G H J) | 37 (A B C D) | 50 (F G H J) | 63 (A B C D) | |
| 12 (F G H J) | 25 (A B C D) | 38 (F G H J) | 51 (A B C D) | 64 (F G H J) | |
| 13 (A B C D) | 26 (F G H J) | 39 (A B C D) | 52 (F G H J) | 65 (A B C D) | |

TEST 2

- | | | | | | |
|----------------|----------------|----------------|----------------|----------------|----------------|
| 1 (A B C D E) | 11 (A B C D E) | 21 (A B C D E) | 31 (A B C D E) | 41 (A B C D E) | 51 (A B C D E) |
| 2 (F G H J K) | 12 (F G H J K) | 22 (F G H J K) | 32 (F G H J K) | 42 (F G H J K) | 52 (F G H J K) |
| 3 (A B C D E) | 13 (A B C D E) | 23 (A B C D E) | 33 (A B C D E) | 43 (A B C D E) | 53 (A B C D E) |
| 4 (F G H J K) | 14 (F G H J K) | 24 (F G H J K) | 34 (F G H J K) | 44 (F G H J K) | 54 (F G H J K) |
| 5 (A B C D E) | 15 (A B C D E) | 25 (A B C D E) | 35 (A B C D E) | 45 (A B C D E) | 55 (A B C D E) |
| 6 (F G H J K) | 16 (F G H J K) | 26 (F G H J K) | 36 (F G H J K) | 46 (F G H J K) | 56 (F G H J K) |
| 7 (A B C D E) | 17 (A B C D E) | 27 (A B C D E) | 37 (A B C D E) | 47 (A B C D E) | 57 (A B C D E) |
| 8 (F G H J K) | 18 (F G H J K) | 28 (F G H J K) | 38 (F G H J K) | 48 (F G H J K) | 58 (F G H J K) |
| 9 (A B C D E) | 19 (A B C D E) | 29 (A B C D E) | 39 (A B C D E) | 49 (A B C D E) | 59 (A B C D E) |
| 10 (F G H J K) | 20 (F G H J K) | 30 (F G H J K) | 40 (F G H J K) | 50 (F G H J K) | 60 (F G H J K) |

TEST 3

- | | | | | | |
|-------------|--------------|--------------|--------------|--------------|--------------|
| 1 (A B C D) | 8 (F G H J) | 15 (A B C D) | 22 (F G H J) | 29 (A B C D) | 36 (F G H J) |
| 2 (F G H J) | 9 (A B C D) | 16 (F G H J) | 23 (A B C D) | 30 (F G H J) | 37 (A B C D) |
| 3 (A B C D) | 10 (F G H J) | 17 (A B C D) | 24 (F G H J) | 31 (A B C D) | 38 (F G H J) |
| 4 (F G H J) | 11 (A B C D) | 18 (F G H J) | 25 (A B C D) | 32 (F G H J) | 39 (A B C D) |
| 5 (A B C D) | 12 (F G H J) | 19 (A B C D) | 26 (F G H J) | 33 (A B C D) | 40 (F G H J) |
| 6 (F G H J) | 13 (A B C D) | 20 (F G H J) | 27 (A B C D) | 34 (F G H J) | |
| 7 (A B C D) | 14 (F G H J) | 21 (A B C D) | 28 (F G H J) | 35 (A B C D) | |

TEST 4

- | | | | | | |
|-------------|--------------|--------------|--------------|--------------|--------------|
| 1 (A B C D) | 8 (F G H J) | 15 (A B C D) | 22 (F G H J) | 29 (A B C D) | 36 (F G H J) |
| 2 (F G H J) | 9 (A B C D) | 16 (F G H J) | 23 (A B C D) | 30 (F G H J) | 37 (A B C D) |
| 3 (A B C D) | 10 (F G H J) | 17 (A B C D) | 24 (F G H J) | 31 (A B C D) | 38 (F G H J) |
| 4 (F G H J) | 11 (A B C D) | 18 (F G H J) | 25 (A B C D) | 32 (F G H J) | 39 (A B C D) |
| 5 (A B C D) | 12 (F G H J) | 19 (A B C D) | 26 (F G H J) | 33 (A B C D) | 40 (F G H J) |
| 6 (F G H J) | 13 (A B C D) | 20 (F G H J) | 27 (A B C D) | 34 (F G H J) | |
| 7 (A B C D) | 14 (F G H J) | 21 (A B C D) | 28 (F G H J) | 35 (A B C D) | |

ACT STUDENT REVIEW: The test supervisor will give you instructions for completing this section.



Student Review: Your responses to these items will assist ACT and your test center in providing the best possible conditions for testing and planning for the future. Fill in the oval indicating your response to each item printed on the back of your test booklet.

- | Yes | No | Yes | No | Yes | No |
|-------------------------|-----------------------|--------------------------|-----------------------|--------------------------|-----------------------|
| 1 <input type="radio"/> | <input type="radio"/> | 6 <input type="radio"/> | <input type="radio"/> | 11 <input type="radio"/> | <input type="radio"/> |
| 2 <input type="radio"/> | <input type="radio"/> | 7 <input type="radio"/> | <input type="radio"/> | 12 <input type="radio"/> | <input type="radio"/> |
| 3 <input type="radio"/> | <input type="radio"/> | 8 <input type="radio"/> | <input type="radio"/> | 13 <input type="radio"/> | <input type="radio"/> |
| 4 <input type="radio"/> | <input type="radio"/> | 9 <input type="radio"/> | <input type="radio"/> | 14 <input type="radio"/> | <input type="radio"/> |
| 5 <input type="radio"/> | <input type="radio"/> | 10 <input type="radio"/> | <input type="radio"/> | 15 <input type="radio"/> | <input type="radio"/> |

Improve Your Test Scores with Strategy, Practice, and Insight

ACT *Online Prep*™

The only ACT test preparation program designed exclusively by development professionals is now online!

Here's what you will find in ACT Online Prep:

- Practice tests with real ACT test questions
- Comprehensive content review for each of the four required tests—English, Math, Reading, and Science
- Practice essays, with real-time scoring, for the optional ACT Writing Test
- Anywhere, anytime access via the Internet
- Only \$19.95

The Real ACT Prep Guide

- This official ACT prep guide is the only one that includes three actual ACT tests.
- Get all the facts about the ACT Writing Test.
- Develop valuable test-taking strategies.
- Learn how to prepare for test day.
- Only \$25.00 (includes shipping and handling)

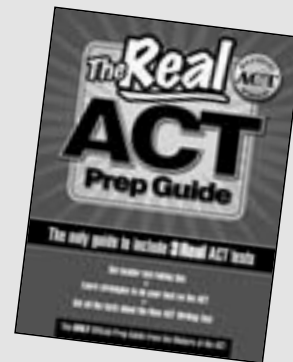

Visit www.actstudent.org
to order both.